

The logo for MAX is rendered in a large, bold, 3D-style font. Each letter has a metallic gradient and a beveled edge, giving it a sense of depth and power.

P O W E R

THRUST IT TO THE MAX

CT300

With electronic thruster control

INSTALLATION OPERATION MAINTENANCE

Serial No.:

Installation date:

THIS MANUAL MUST BE KEPT ONBOARD AT ALL TIMES

Via Philips 5, 20900 Monza (MI), Italy
Tel. +39 039 200 1973-936 - Fax +39 039 2004299
www.max-power.com E-mail: contact@max-power.com

Contents

Section	Title	Page
1	General installation guidelines	2
2	Tunnel	3
3	Motor support and drive leg	4
4	Electric Motor	5
5	Propellers	5
6	Protection grids	5
7	Electrical installation	5
8	Main power fuse	6
9	Batteries	6
10	Electronic control box	7
11	Control panel and thruster control box functions	7
12	Control panel installation	8
13	Tests	9
14	Electrical measurements	9
15	Operation	9
16	Alarms or thermal switch-off	10
17	Safety	10
18	Maintenance	10
19	Electrical installation diagram	11
20	Power cable connections diagram	12
21	Spare parts diagram	13
22	Spare parts list	14
23	Troubleshooting guide	15
24	Worldwide distribution network	15
25	Warranty coverage	16
26	Warranty form	18

The use of **qualified marine personnel**, with experience in bow thruster installation, is strongly advised. Where possible, the boat manufacturer's design departments, architects, and/or shipyards should be consulted, prior to installation taking place. For any boat requiring official classification, bodies of approval should also be consulted at the earliest opportunity. In any case, all other bodies, governmental or otherwise, should be contacted to ensure conformity with legal regulations relating to the boat in question.

IT IS ESSENTIAL TO READ THE FOLLOWING MANUAL CAREFULLY BEFORE INSTALLING THE THRUSTER

NB : The thruster is delivered without accessories (fuse, fuse holder, control panel).

1. GENERAL INSTALLATION GUIDELINES

In order to install the thruster in the most efficient position, follow the instructions below:

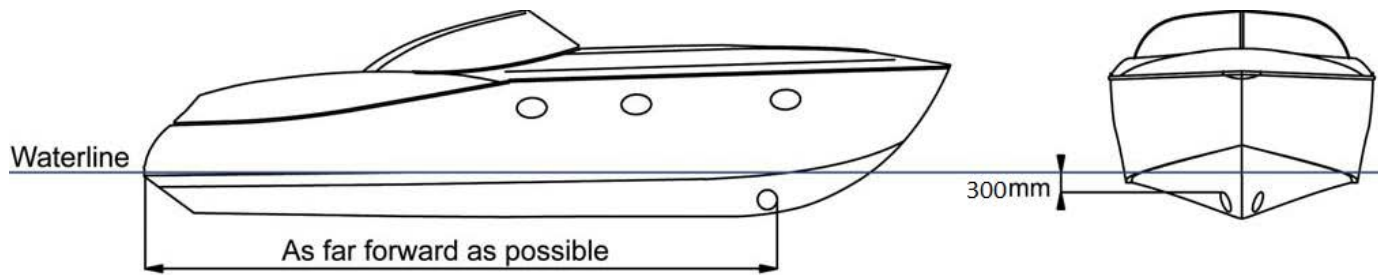

- The **minimum** acceptable tunnel position is 225mm below the waterline
- **The tunnel is ideally positioned when the distance between the waterline and the top of the installed tunnel is 300mm**
- The tunnel must be installed as far forward as possible

NB: A thruster turbine installed above its ideal position towards its minimum depth will lead to a progressive loss of performance.

Whether vertical, inclined or horizontal, it is recommended to support the electric motor.

The electric motor generates heat when in operation. The zone in which the thruster is installed must therefore be dry and ventilated.

The batteries used by the thruster must be charged by both the main engine's alternator and an appropriate battery charger.

If the thruster is installed using a dedicated battery bank, this must be as close as possible to the thruster in order to reduce voltage loss in the electric cables.

CAUTION: In no case should flammable products be stored near to the electric components of the motor.

The drive leg must be centered in the tunnel and **under no circumstances should the propellers protrude out of the tunnel.**

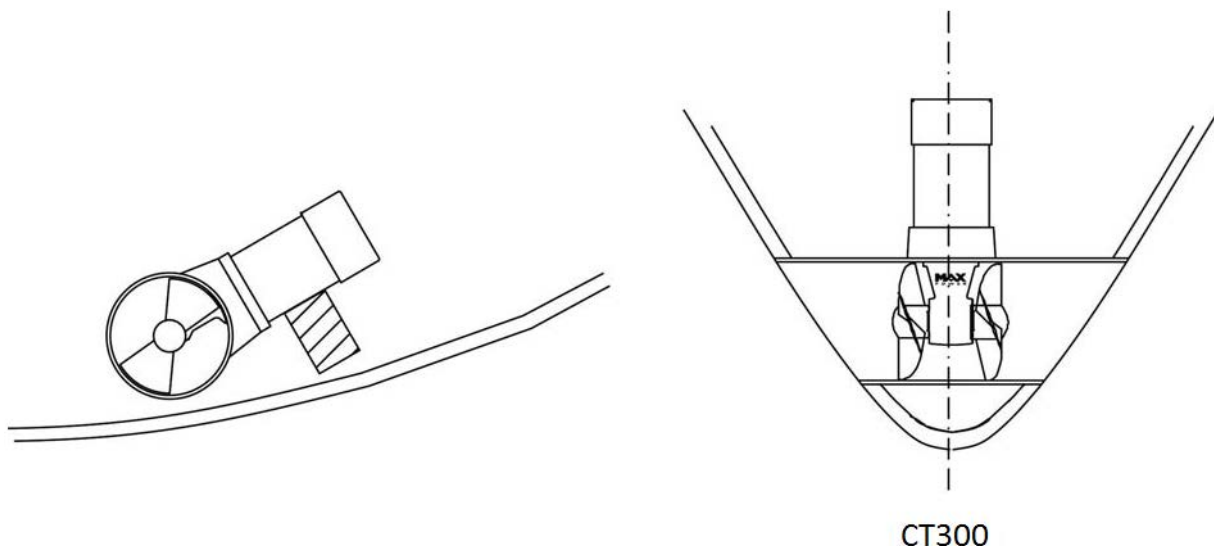

2. TUNNEL

Once the final tunnel position has been determined and all dimensions have been checked, mark the centre-point of the tunnel on both sides of the hull and drill holes of 8 –10mm \varnothing on either side.

Using a metal rod, construct a compass with a 161mm radius. Insert through the holes and trace the ellipses, as shown below.

After cutting the holes out following the elliptical guidelines, use an abrasive disc to prepare the inside and outside surfaces of the hull for laminating (approx. 10 to 15cm around the holes).

Position the tunnel in the hull, mark the positions of the different components, as well as the areas that require laminating, then remove the tunnel. It is advisable to drill the tunnel before laminating it into position. See section 3 "Motor Support and Drive leg" for more details.

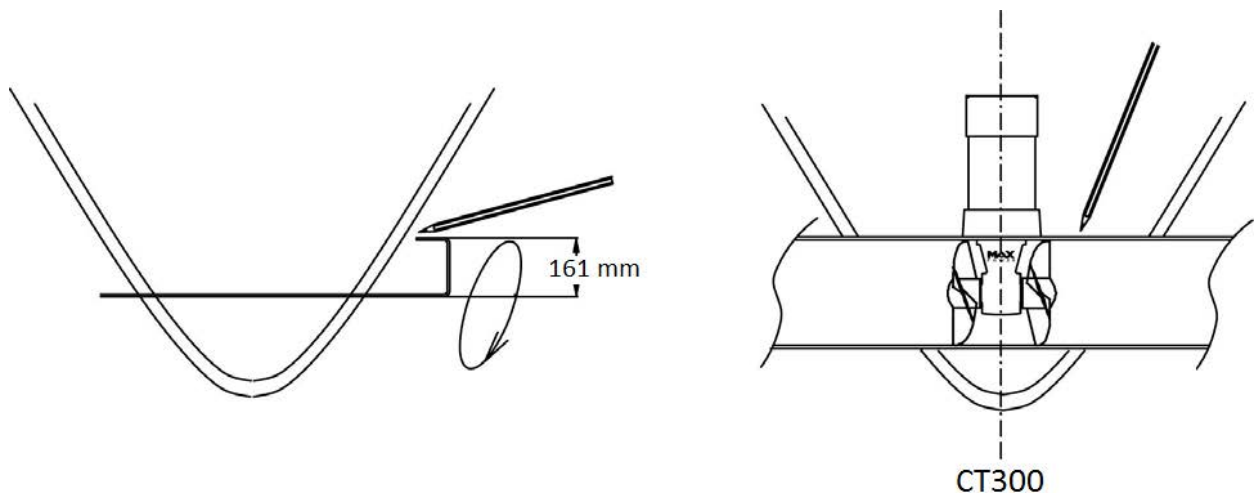

Replace the tunnel. To secure its position apply reinforced fibreglass filler to all areas, both inside and out, taking care to entirely fill the space between the hull and the tunnel. Laminate using a minimum of 8 layers of **ISOPHTALIC RESIN** alternated with mat and roving.

In difficult to access areas (i.e. under the tunnel), it is possible to only apply reinforced filler.

Once the filler has set on the outside, finish with a waterproof under coat, followed by sanding and application of a waterproof finish coat.

In order to optimise the flow of water whilst sailing, and to avoid turbulence due to the tunnel, leave 1 to 4 cm of Finish these with several coats of reinforced filler in order to obtain the required hydrodynamic lines.

Once all laminating work is complete, apply a watertight barrier.

DO NOT LAMINATE THE AREA OF THE TUNNEL TO WHICH THE ELECTRICAL MOTOR SUPPORT WILL BE FIXED.

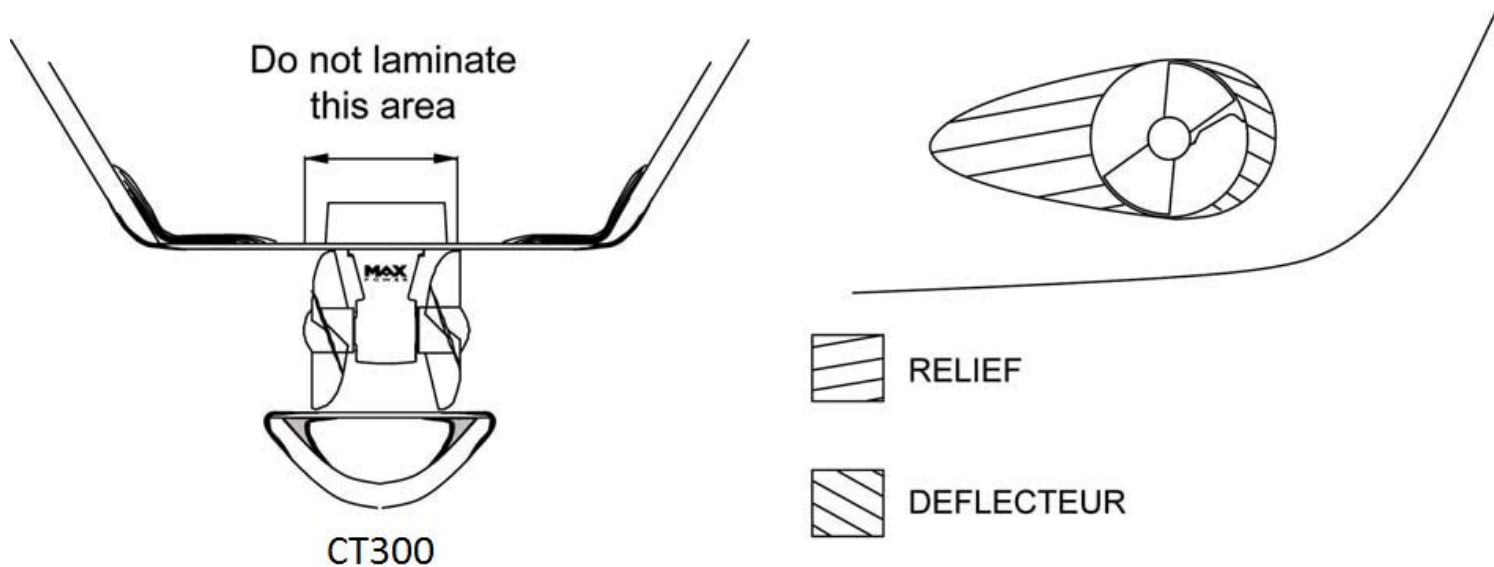

3. MOTOR SUPPORT AND DRIVE LEG

The motor support and the drive leg must be centered in the tunnel.

Locate and mark the intended position of the holes for the fixing screws and the leg hub. You can use the motor support and the leg's gasket to mark these holes.

In some cases it will be easier to mark and drill these holes **BEFORE** laminating the tunnel.

After drilling, use the gasket to verify the holes' axes and adjust them with a round file where necessary.

These holes must be completely **clean** before inserting the screws.

Position the leg, the gasket (**between the leg and the tunnel**) and the motor support, and then tighten the the two screws alternatively. Finally, mount the propeller(s) to control the general alignment.

If the general set-up is correct, remove the propeller(s), the leg and the gasket.

Apply a thin coating of silicon grease or sealing compound to both sides of the gasket (this must be resistant to hydrocarbons and water). Re-assemble all parts as before, positioning and then tightening the two 12mm \varnothing screws alternatively, using a 8mm Allen key, (maximum torque: 50Nm).

Check that the propellers rotate freely, without resistance or friction.

It is imperative that the holes and the screws remain free of sealing compound, otherwise there is a risk of an incorrect assembly of the parts.

Caution: do not use graphite grease.

4. ELECTRIC MOTOR (12 / 24 volts)

The upper coupling (motor side) is adjusted in the factory. Position the lower coupling on the drive leg shaft and push it down as far as it will go (lightly grease the shaft beforehand).

Place the flexible red coupler on the drive leg side coupling, **(part n° 5 on the CT300 – Spare Parts diagram, page 13)**

Now fit the electric motor onto the motor support and tighten the four 12mm Ø motor support screws alternatively (maximum torque: 40Nm).

Push the lower coupling up into place using a screwdriver et tighten the two 4 x 10mm Allen screws (maximum torque: 10Nm).

The upper and lower couplings must be adjusted to leave 2mm of play (+/- 1mm) between both of them.

Check that the propellers turn without resistance (a little resistance due to the motor is normal).

Ensure that air can flow freely to allow the motor to cool whilst in operation.

Please note that the motor side coupling is already in position and does not need adjusting.

5. PROPELLERS

Insert the drive pin and propellers.

Check that the propellers turn without resistance (a little resistance due to the motor is normal).

Check that the oil change screw and the anode are in place and correctly tightened.

Position the propeller blades so as the y are not in horizontal alignment and not directly opposite each other.

Tighten the 24mm nut (maximum torque: 30Nm) while holding the propeller tightly with your hand.

Protect your hands during this operation to avoid risks of injuries caused by the edges of the propeller.

IMPORTANT: to prevent against calcium deposits that damage the seals, we recommend that you coat the shaft and stainless steel cover with silicon grease.

6. PROTECTION GRIDS

It is possible to install protection grills; however installation of such grills will affect thruster performance.

7. ELECTRICAL INSTALLATION

CAUTION: an incorrect electrical installation will cause rapid deterioration or even failure of the thruster. Excessive voltage drop will cause premature wearing of the relays and brushes. Special attention should be given to the quality, capacity and condition of your batteries, as well as cable sections used.

Ensure that all electrical connections are correctly tightened.

Under no circumstances should any flammable products be stored next to the electrical components of the thruster.



It is essential to install a manual battery isolator and if possible an electric battery isolator at the base of the thruster motor power line.

When using a manual battery isolator it must be visible, clearly marked & easily accessible.

Thruster motor power supply (24V):

These values are given as an indication, assuming that the batteries are charged at 100% and in charge, that is 25.4V.

The performance data of the CT300 is measured with an approx. consumption of 980A and 22V at the motor's connections.

Please refer to the characteristics given by the manufacturer of the batteries that will be used (see section 9 "Batteries").

Power wiring:

Measure the shortest and most direct route possible between the battery(ies) and the electric motor; remembering to allow for both "positive **and** negative" cables.

Recommended cable sections:

Cable lengths	CT300
$L \leq 5 \text{ m } (2,5 \times 2)$	95mm ²
$5 < L \leq 10 \text{ m } (5 \times 2)$	150mm ²
$10 < L \leq 15 \text{ m } (7,5 \times 2)$	200mm ²
$15 < L \leq 20 \text{ m } (10 \times 2)$	240mm ²

For all connections, use appropriate terminals for the cable sections chosen.

It is possible to reduce the cable section to facilitate easy connection but **only over a short distance**. In this case, appropriated crimp fittings should be used at the connections.

Please consult the "Electrical installation" diagram p. 11 for more information

8. MAIN POWER FUSE

Fuse sizes for overcurrent protection are to be determined on the basis of the cable sections in the circuit and NOT the amperage drawn by the appliance (thruster motor) in the circuit.

Thruster	Maximum Amperage	Max Power Fuse size
CT300 / 24V	980A	400A

9. BATTERIES

Thrusters are high amperage consumers with instantaneous demands, thus, we recommend you use maintenance-free "starting" type batteries, with high CCA outputs.

For example: Exide Maxxima 900, 12V, capacity 55Ah / starting current 800CCA.

10. ELECTRONIC CONTROL BOX

Install a fused circuit breaker / switch in the boat's main DC distribution panel marked BOW THRUSTER.

This circuit breaker / switch should ideally be supplied from a different battery bank to the one used for powering the thruster.

The installer must protect the positive supply cable of the thruster's control box by means of a 8A fuse. The size of the power cables (red & black) depends on the length of the cable run, the voltage drop in these cables should not exceed 5% of the nominal battery voltage.

For safety reasons, and in order to obtain all the functions provided by the thruster controller, an electric battery isolator needs to be installed in the thruster motor positive supply cable.

Max Power advises the use of an electric battery isolator ref. HF1 I €F.

If an electric battery isolator is not used then simply seal-off the two grey wires coming out of the control box. It is important to isolate the thruster motor power circuit by means of a manual battery isolator after having used the thruster.

Please refer to the drawing "Power cable connections" p. 12 for more detail on the wiring of the control box to the thruster.

11. CONTROL PANEL AND THRUSTER CONTROL BOX FUNCTIONS

To switch the thruster ON or OFF follow the instructions given in the diagrams on the following page.

When switched ON the control panel will beep once and the green LED in the red push-button will light up.

When switched OFF the control panel will beep twice and the green LED in the red push-button will go out.

The thruster controller provides a time delay between left and right thrust in order to avoid rapid direction changes. There is no delay when thrusting to same side.

If the thruster motor overheats the control panel will start beeping and the green LED will flash until the thruster motor has cooled down.

As soon as the overheating alarm sounds, there are 10 seconds of actual thruster use before the unit automatically shuts down. It will then not be possible to switch the thruster on until the motor has cooled down.

If the thruster has not been used for a period of thirty minutes it will automatically switch itself off.

Before switching off automatically the control panel will beep once followed by a second beep a few seconds later, after which the thruster switches itself off.

In order to isolate the thruster motor power circuit, as described in the previous two paragraphs, it is necessary to install an electric battery isolator, as advised by Max Power.

Please consult the "Electrical installation" diagram p. 11 for more information

Control Panel Instructions

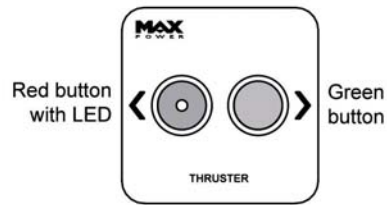

Touch panel :

To switch the thruster on or off, **push and hold down both the red and green buttons** for several seconds.

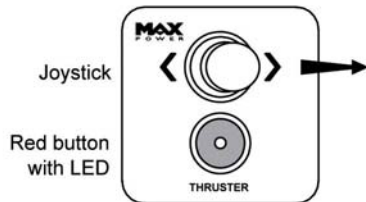

Simple Joystick :

To switch the thruster on or off, push and hold down the red button whilst pushing the joystick to the right for several seconds.

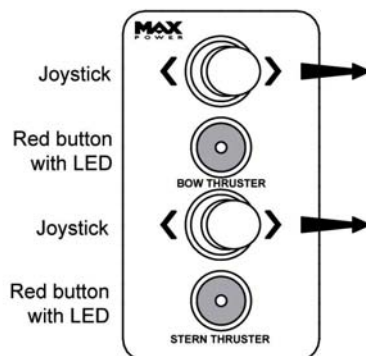

Double Joystick :

To switch the thruster on or off, push and hold down the red button whilst pushing the joystick to the right for several seconds. This is the same for both the Bow thruster and the Stern thruster.

12. CONTROL PANEL INSTALLATION

Control panels should be protected from the natural elements while the thruster is not in use.

Install the control panel(s) in easily accessible positions, without obstructing the main engine and/or steering controls.

When fixing the panel with the stainless steel screws, make sure to install the pre-cut rubber seal, as supplied with the panel, ensuring that it is in the correct place.

 Only when totally finished and satisfied with the wiring and positioning of the unit, clip-on the face panel/cover.

Please note that panels are only fully waterproof from the front, if installed correctly. However the area behind the dashboard should be kept dry to avoid the risk of oxidization of the cable connector contacts.

For full control panel installation instructions, please refer to the "Installation Guidelines" as supplied with each control panel.

13. TESTS

 **Activating the thruster when the boat is out of the water, is not advised under any circumstances.**

Tests must be carried out with the boat in the water, the battery(ies) charged at 100% and in charge, and the engines running.

The maximum continuous operating runtime corresponds to S2-3mn norm.

However, this can be affected by the ambient temperature.

14. ELECTRICAL MEASUREMENTS

In normal "usage" mode, i.e. thrusters running, boat in the water, with fully charged batteries under ongoing charge (alternator), electrical measurements should be made at the following points:

At the batteries

At the battery cut-off switch

At the fuse

At the electric motor's connections

At the power supply arriving at the thruster control box

These measurements will enable you to detect voltage drop.

NOTE: the voltage reading between the motor's negative and positive connections should be approx. **22V for a 24V system**.



The cumulative effect of voltage drops at these points can severely impair the thruster's performance.

Should the voltage measured be too low, the following points need checking:

Are the batteries of sufficient capacity ?

Are the batteries good quality?

Are the batteries sufficiently charged?

Are appropriate cable sections being used?

Are the connections sufficiently tightened?

15. OPERATION

With the control system circuit breaker/ switch and manual battery isolator switched on:

Switch on the control panel, as previously described in the manual.

Push the red button or incline the joystick to the left and the boat moves to the left.

Push the green button or incline joystick to the right and the boat moves to the right.

If, during tests the boat moves in the wrong direction, change around the blue and the brown wires on your power relay.

When manoeuvring remember that the boat's momentum continues after you release the joystick / button, therefore remember to release the control prior to reaching your desired position.

Care must be taken not to use the thruster in areas where there may be people swimming or floating debris.

Maximum running time: 2-3 min (depending on ambient temperature).

16. ALARMS OR THERMAL SWITCH-OFF

The thruster's electric motor is fitted with a thermal switch as standard. If the thruster motor overheats the buzzer in the control panel will start beeping and the green LED in the red-push button will flash until the thruster motor has cooled down again.

As soon as the overheating alarm sounds, there are **10 seconds of actual thruster use** before the unit automatically shuts down. The unit will then not be able to be switched on again until the motor has cooled down.

17. SAFETY

Switch off means to cut the power at both the DC equipment panel (control power supply) & the thruster battery isolator (thruster power supply) after having used the thruster. Under no circumstances should any flammable products be stored next to the electric components of the thruster. Care must be taken not to use the thruster in areas where there may be people swimming or in the water close to the thruster.

CAUTION: Never tamper with the thruster / thruster turbine if not 100% sure that both the control and power circuits have been isolated, except if taking electrical measurements on the thruster motor or relay.

18. MAINTENANCE

Control panels should be protected from the natural elements while the thruster is not in use.

The thruster requires a minimum of ongoing maintenance:

Check the condition and charge of the batteries regularly, as voltage drop is the most frequent cause of rapid deterioration of the relay.

Carry out a regular check of all electric components: batteries, connections, power cables.

Remove the motor and clean out dust from the motor-brushes with compressed air.

The electric motor must be kept dry and well-ventilated.

Change the drive leg oil every year. See diagram below:

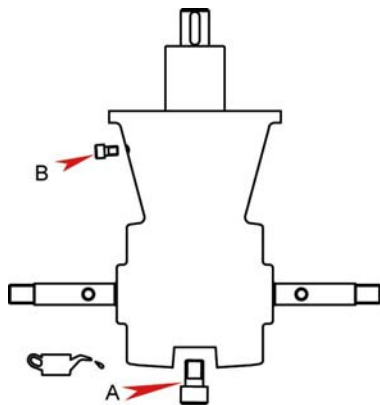

Check the oil in the leg annually.

Change if necessary: oil drain plug under the anode (A).

Oil level screw on the side of the leg (B).

Copper washer should be changed.

The anode should be checked frequently and changed if necessary (at least once a year).

If you find water in the oil, it is necessary to change the propeller shaft oil seals.

The anode must be checked frequently and changed if necessary (at least once a year).

When the boat is out of the water, check that there are no fishing lines, plastic bags, etc. caught in the propellers.

Paint the drive leg and propellers with antifouling (make sure that they were well prepared and primer has been used).

Do not paint the anode.

Always keep the propellers and tunnel clean.

To prevent the build up of calcium on the drive shafts, which would damage the oil seals, cover the drive shaft and the oil seals' stainless steel covers with silicon grease before fitting the propeller(s). This should be done on an annual basis after the cleaning of the outside of the leg. Do not use aggressive solvents as they may damage drive leg seals.

If drive leg oil seals are found to be worn, replace the drive leg with a standard exchange unit.

NOTE: All maintenance should be carried out by qualified and authorised personnel.

THE MAX-POWER TEAM WISHES YOU SUCCESSFUL MANOEUVRING AND ENJOYABLE CRUISING

19. ELECTRICAL INSTALLATION DIAGRAM



CT300 - Electrical Installation Diagram

NB: This diagram is intended as a guide only. Any local rules or regulations requiring additional equipment in high current circuits must be respected.

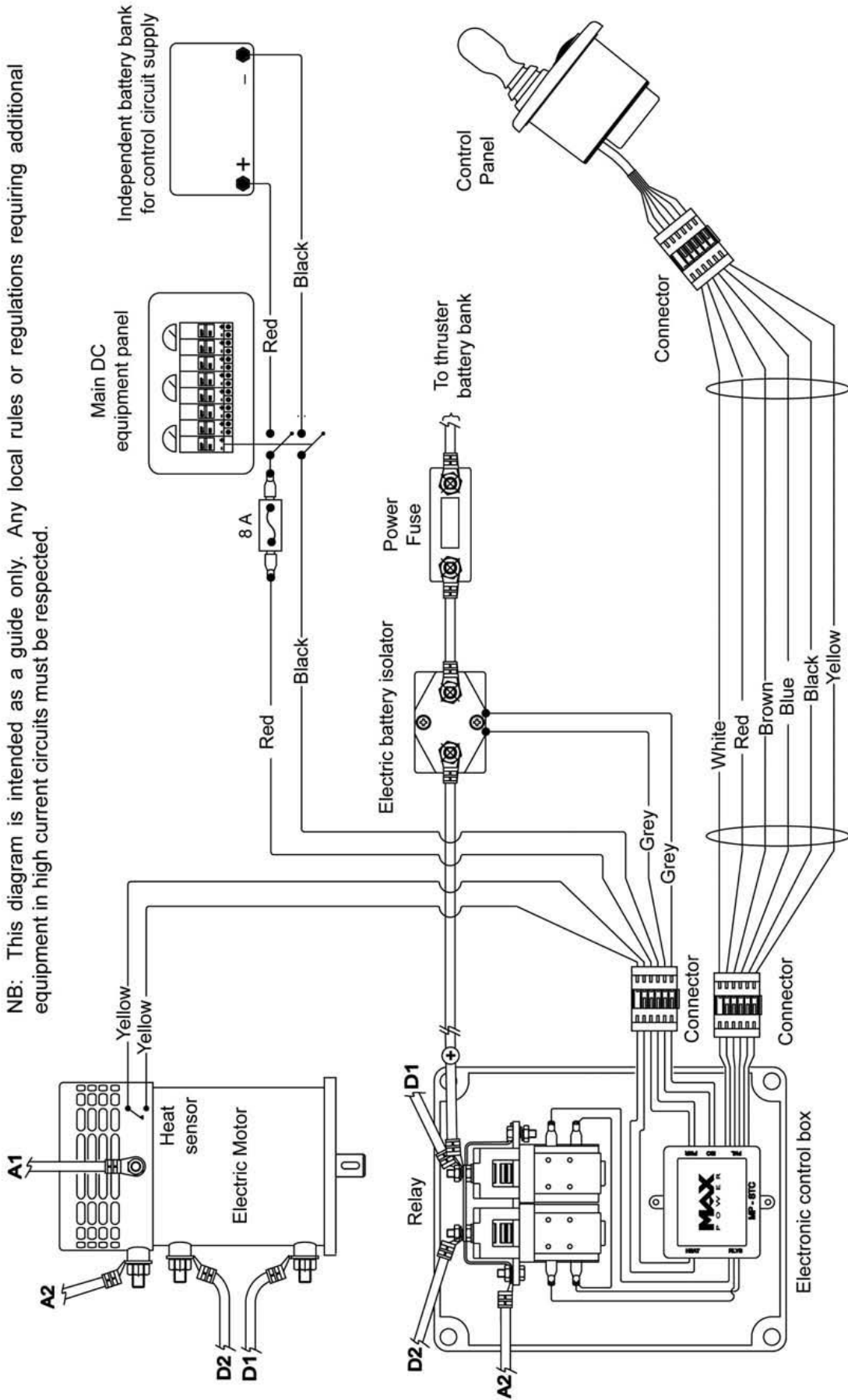

20. POWER CABLE CONNECTIONS



CT300 - Power Cable Connections

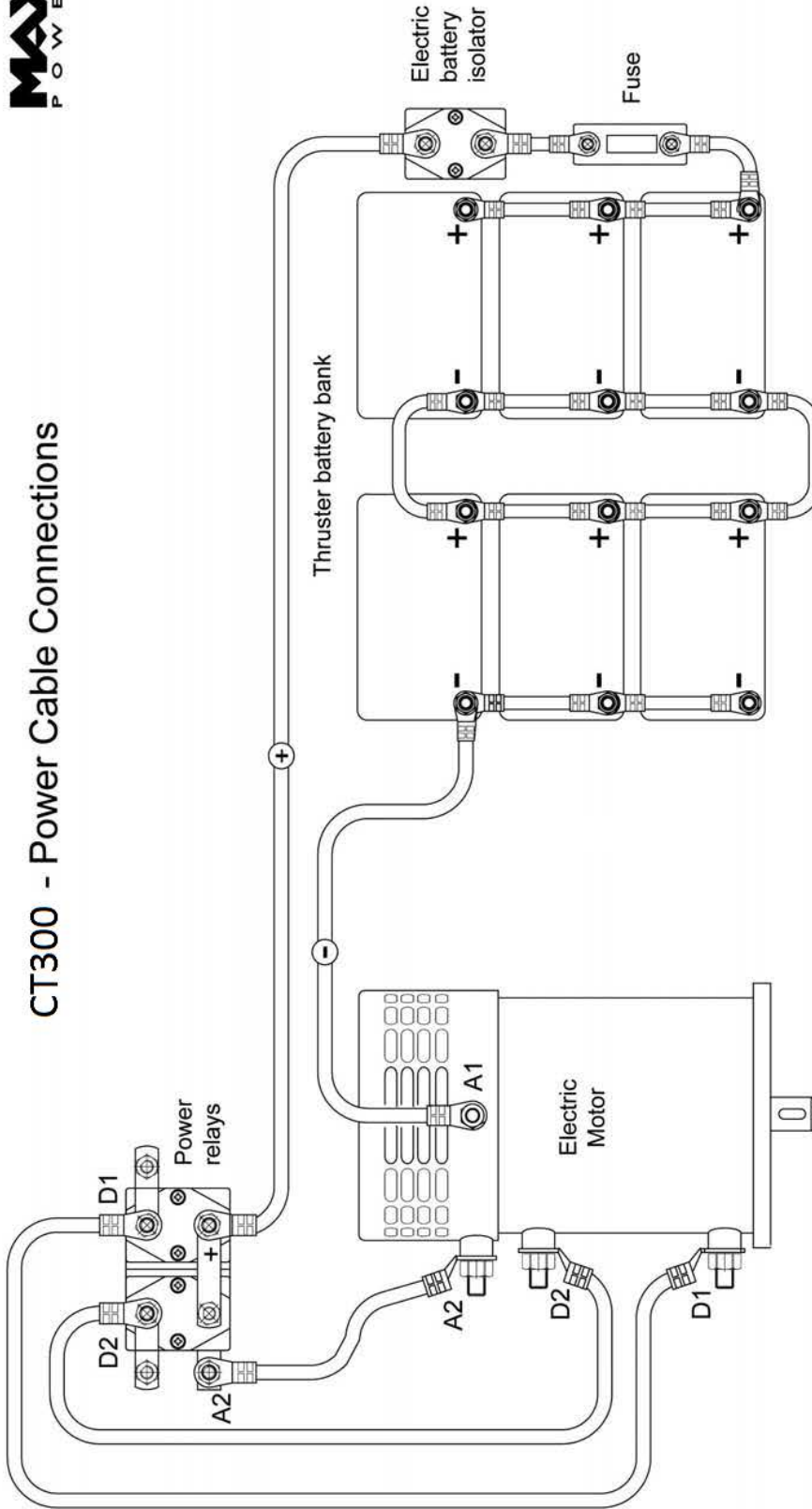

NB:

1. All cables must have the same section size (see recommended sizes in this manual).

2. The thruster battery bank must be installed as near to the thruster motor as possible to limit cable sizes.

21. SPARE PARTS DIAGRAM

CT300 - Pieces Detachees

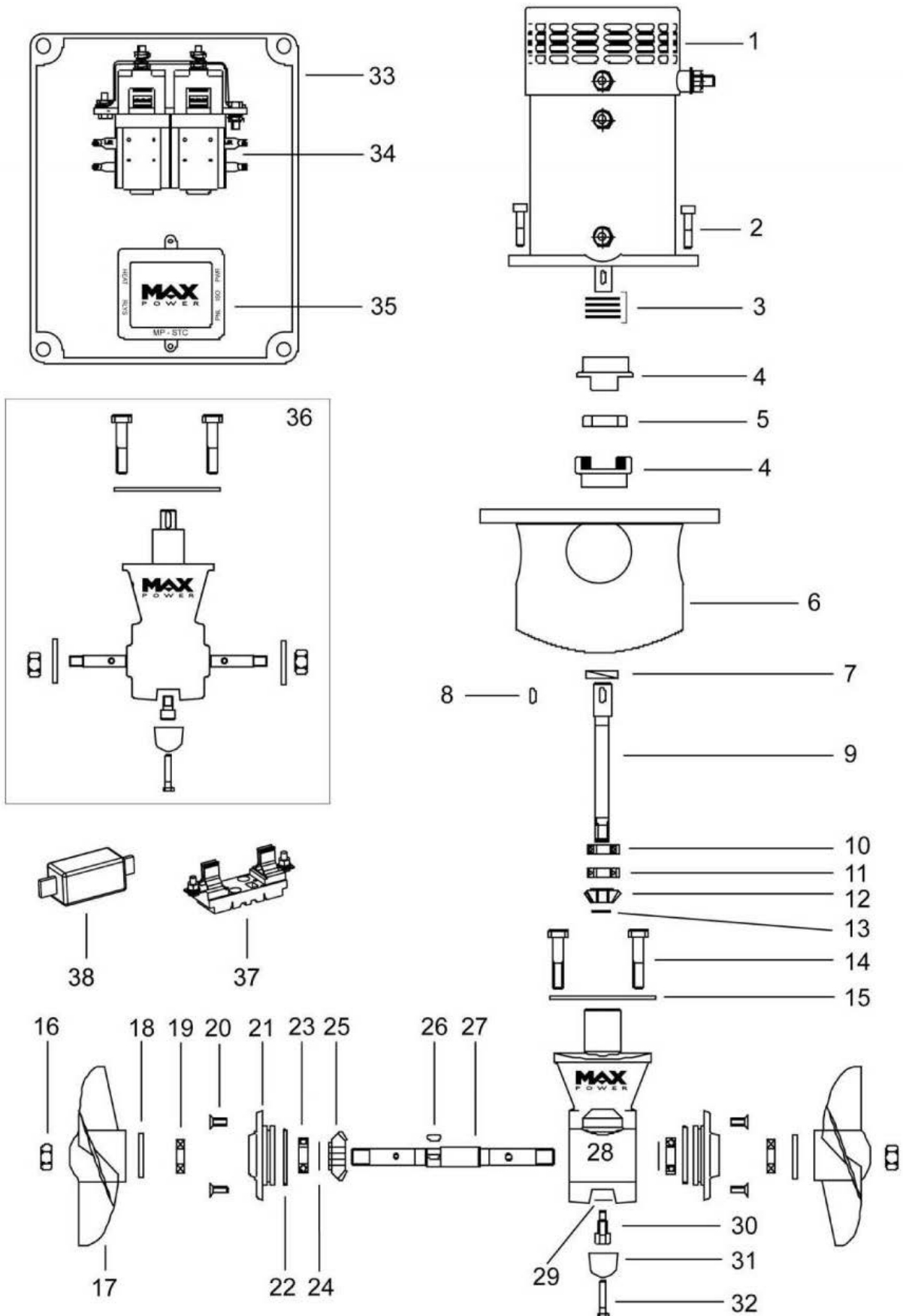

22. SPARE PARTS LIST

N°	Description	Quantity	Old Code	New Code
1	Electric Motor CT300	1	MP203000	312862
	Motor Brushes	8	MPOP3559	310382
	Spring	8	MPOP3520	310383
2	Screws	4	MPOP4070	630496
3	Rondelles	4	-	
4	Coupling aluminium	2	MP662000	633751
5	Coupling PG66	1	MP661000	633749
6	Motor Support CT300	1		633740
7	Ring	1	MP205038	633712
8	Shaft Pin	1	MP205035	312020
9	Gearbox main Shaft	1	MP205040	310116
10	Bearing	1	MP205045	310342
11	Lower Bearing	1	MP205050	310341
12	Gearwheel	1	MP205001	633701
13	Circlips	1	MP205002	310295
14	Screws	2	MP204000	630507
15	Leg gasket	1	MP205055	310253
16	Inox Nut	2	MP204005	633697
17	Propeller300	2	MP205015	313810
18	Propeller Pin	2	MPOP5530	312059
19	Propeller seal	2	MP205065	310276
20	Screws	4	MP204010	630504
21	Flange	2	MP205095	310214
22	Flange seal	2	MP205090	310257
23	Propeller bearing	2	MP205085	310348
24	Set of spacers (1 mm)	2	MP205080	310226
25	Propeller gearwheel	1	MP205006	630483

26	Pin for propeller shaft	1	MP205035	312020
27	Propeller shaft	1	MP205070	310117
28	Leg body	1	MP205060	633717
29	Seal	1	MPOP2050	310248
30	Screw	1	MPOP5300	312131
31	Anode	1	MPOP5390	630506
32	Anode screw	1	MPOP5311	312120
33	Relay and Control box assembly	1	MP208055	315334
34				
	Relay 24 V	1	MP203101/2	312922
35	Electronic Controller	1	MPOP5701	315308
36	Metal leg CT300	1	MP208100	315388
37	Fuse holder T2	1	OPTI3091	35018
38	Fuse 400 A	1	OPTI3145	35028
-	Extraction handle for T1 & T2	1	OPTI3118	312882
-	Heat sensor	1	MPOP3720	311363

23. TROUBLESHOOTING GUIDE

Before contacting your nearest Max Power distributor, please check the below troubleshooting guide.

Problem	Check
The control panel does not light up	<ul style="list-style-type: none"> • Check the 6 wire connector behind the joystick • Check the thruster's electronic control box 6 wire connector • Check the circuit breaker / switch in the boat's main DC distribution panel • Check the control box's power fuse (8 A)
The relay is clicking but the motor is not running	<ul style="list-style-type: none"> • Check the motor's power fuse • Check the main battery isolator • Check the internal relay contacts • Check battery conditions and connections
The motor is running but the thruster is not working	<ul style="list-style-type: none"> • Check the propellers are fitted • Check the motor / drive leg assembly • Check that the tunnel is not obstructed or the propellers blocked
The thruster lacks power	<ul style="list-style-type: none"> • Check the propellers are fitted • Check the size of the batteries • Check the batteries are sufficiently charged • Check the connections are tightened correctly • Check the power cables sections (See p. 6 : Recommended cable sections)

24. WORLDWIDE DISTRIBUTION NETWORK

To locate the nearest Max Power distributor, please consult the section "*Worldwide Distribution*" on our website: www.max-power.com

Introduction

The purpose of this document is to set out the terms of warranty cover offered in relation to products purchased by the End User from Max Power or its approved network of resellers.

1. Definitions

- **Authorized Repair Number:** The number given by Max Power on reporting a fault with your thruster
- **Dealer:** An authorized Max Power sales centre
- **End User:** The boat supplied with supplied equipment and the owner thereof
- **Installer:** The authorized centre responsible for the installation of your thruster
- **Manufacturer:** supplier of the equipment under warranty
- **Pleasure Craft:** Vessels used for owner's personal use that have no commercial use (i.e Charter boats or work boats)
- **Resellers:** Max Power approved distributors and dealers
- **Serial Number:** Number in upper right hand corner of Warranty document
- **Supplier:** The manufacturer (Max Power)
- **Warranty:** The terms and conditions that are covered by the manufacturer

2. Period of Coverage

The equipment manufactured by the Supplier is guaranteed to be free from defective workmanship, components and materials under normal usage conditions for a period of three (3) years from the date of purchase by the End User. This warranty is transferable to subsequent owners of this equipment during the period of coverage.

3. Warranty Registration

Register your purchase now at www.max-power.com. (NB. proof of purchase must be kept throughout the warranty period)

4. Warranty Terms

If the material is used for anything other than for pleasure craft, the guarantee is limited to a six-month period.

Year 1: All factory testing, diagnosis, repairs and replacements are performed at no charge to the End User; All parts and up to two hours of labour are covered for repairs and replacements conducted in the field.

Year 2 & 3: All factory testing, diagnosis, repairs and replacements are performed at no charge to the End User.

This excludes any damage or faults occurring from normal wear and tear on the following items: engine, oil seals, relay contacts (If warranty is registered within the 3 month period following installation)

5. Warranty Exclusions

- Damage due to modifications or installation contrary to published specifications
- Cost of hauling the boat
- Damage due to repairs performed by an unauthorized service centre
- Damage due to lack of normal maintenance services
- Damage due to water
- Parts replaced due to normal wear and tear
- Repairs performed without knowledge of manufacturer (please contact dealer to receive Repair Authorization Number)
- Tampering of equipment by the End User
- Cost of travel to and from the job site
- Cost of economic loss, including injury to any person, damage to property, loss of income or profit, communication, lodging, inconvenience
- Consequential damage due to failure, including those arising from collision with other vessels or objects

6. Procedural Guidelines

PLEASE VIEW THE TROUBLE SHOOTING LIST ON THE MANUAL OF YOUR PRODUCT TO ASCERTAIN OR SOLVE ORIGIN OF PROBLEM PRIOR TO CONTACTING THE DEALER/INSTALLER

1. Contact your dealer/installer to report the problem.
 - If you do not know who this is, contact the nearest Max Power distributor
 - If you are in foreign waters, please contact the nearest Max Power distributor
2. Ensure you have your serial number and model number to hand (top right hand corner of warranty)
3. Dealer/Installer will come to site to decipher the cause of the fault
4. If the cause of fault is due to a manufacturing problem the dealer will contact Max Power to receive Repair Authorization Number.
5. If the problem is due to an installation error please contact your installer.

IF POSSIBLE: PLEASE TAKE PHOTOGRAPHS OF THE THRUSTER TO SHOW PROBLEM

7. Service Centers

Please go online www.max-power.com to find the authorized service station of your area.

The warranty as outlined above is only applicable to Max Power manufactured thrusters and optional equipment as used in marine pleasure industry. The supplier holds the exclusive right to test the product and determine whether it is defective