

Fuel Gauge – Arm & Reed Switch Type Senders

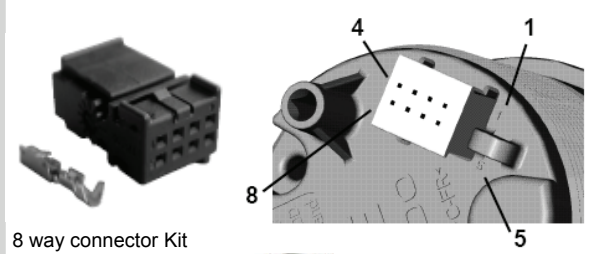

8 way connector Kit
p/n A2C59510850

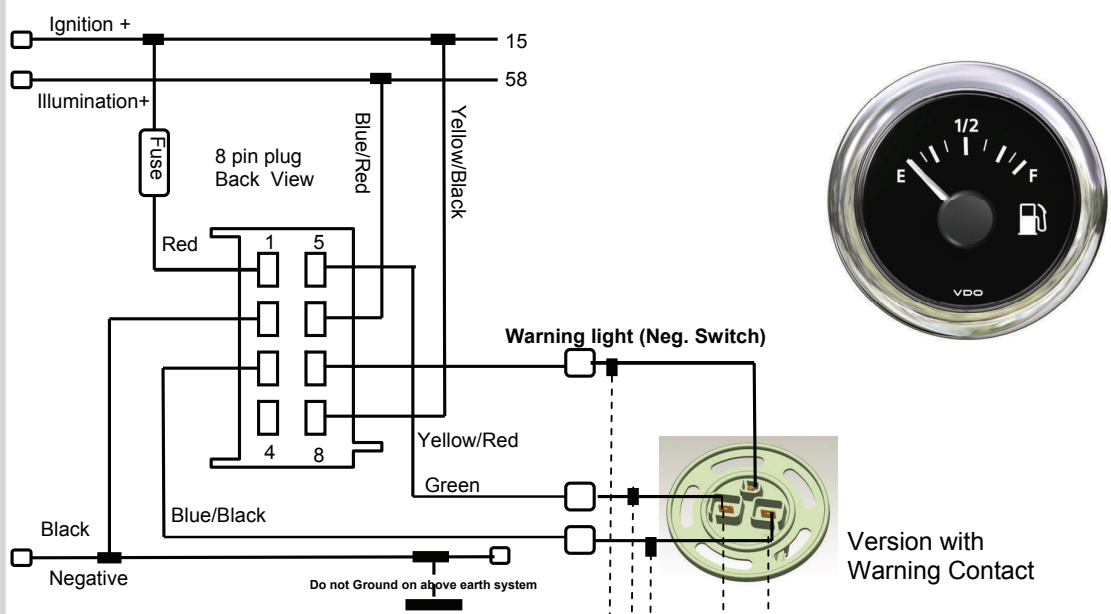
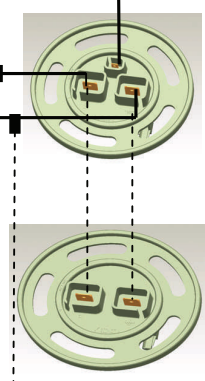

Version with
Warning Contact

Arm type sender

Version without
Warning Contact



Reed Switch sender

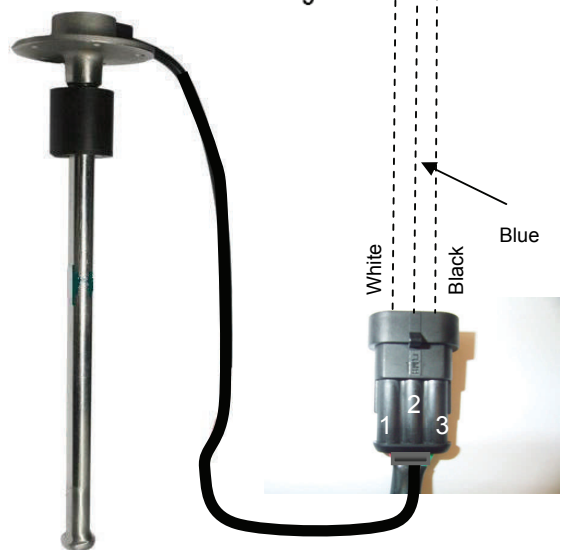

Pin 1 - Wh - Low Fuel Warning
Pin 2 - Bl - Output signal
Pin 3 - Bk - Negative

0 to 1/1

Indication	0	1/4	1/2	3/4	1/1
Resistance (Ω)	3	45	85	138	180
Deflection (°∠)	0	17.2	41.2	73.8	88.8
Tolerance (°∠)	+ 3.6 - 3.6	± 3.6	± 3.6	± 3.6	+ 3.6 - 3.6