

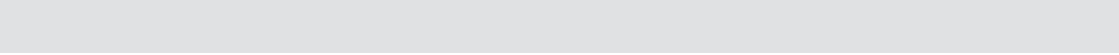

Installation Instructions

V1.1 08/16

AcquaLink 110mm Gauges



Content

Preliminary Remarks	4
Safety Instructions	4
Safety Instructions for Maintenance	6
The VDO 110mm Gauge	7
Components	7
VDO Bus	8
Available versions	8
The NMEA Interface	10
Installation of the VDO 110mm gauge	13
Hardware Specification	16
Pinout	17
Technical Data	18
Accessory	19

AcquaLink 110mm Gauges

Preliminary Remarks

In purchasing a 110mm gauge from the VDO AcquaLink marine range you have decided on a high value product, which has been manufactured according to acknowledged technical standards. Modern production processes and compliance with currently applicable quality assurance standards guarantee that our products leave the factory in perfect condition.

We thank you for making a good choice, and we are convinced that this instrument will be reliable and a great help to you and keep you safe at sea.

In order to ensure easy and safe handling of your VDO 110mm gauge, you should familiarize yourself with all the features and functions.

Please take the time to read these instructions carefully and completely.

Safety Instructions

Installation

This product has been developed, manufactured and tested in accordance with the requirements of EC and UL directives and the acknowledged state of the art.

Please follow all the instructions given in this handbook exactly.



Please pay attention to all text passages labeled with this symbol. These are very important hints for operating and security of the instruments.



Before beginning work the negative Terminal of the battery should be disconnected.

Use of information provided by the VDO 110mm gauge does not release you from the responsibility over your ship and demands good seamanship. Always use your nautical experience in interpreting the displayed values.

If you carry out this work yourself, wear suitable working clothes. Do not wear wide fitting clothes. If you have long hair, wear a hair-net. Clothes and hair can get caught in moving and rotating parts.

Wearing of metallic or conductive jewellery, such as necklaces, bracelets, rings etc. is not allowed when working on the electrical installation on board.

Please note that with disconnection of the battery, all volatile electronic memories lose their input values and must be reprogrammed.



Explosion hazard! Before beginning work on the engine compartment of petrol engines, switch on the ventilator of the engine compartment.

Ensure that necessary clearance is provided behind the cable opening, at the position where the gauge is to be installed.

When selecting the installation position for the gauge, take care that no stringers are drilled. Be careful also of furniture, floorboards, superstructure boxes, cables etc.

When carrying out installation work with a sealing compound, solvent vapours can be formed. Make sure of adequate ventilation and follow the instructions for use of the sealing compound manufacturer.

For the installation only use VDO or NMEA approved cables.

If you don't use standard cables, the wires used should be adequately insulated or should have sufficient electrical strength, and the contact point should be protected against electrical shock hazard. The electrical conducting components of the connected consuming devices should also be protected against direct contact through suitable measures. Installation of bare metallic wires and contacts is not allowed.

Take account of the wire cross section. A reduction of the wire cross section results in a higher current density. This can cause the wire to heat up and potentially cause fire.

Connect the wires only in accordance with the wiring diagram.

Safety Instructions for Maintenance

The 110mm gauge is maintenance-free. Do not use cleaning agents.

Repairs on the gauge should be carried out only by VDO authorized specialists



The VDO 110mm Gauge

The 110mm gauges can be used in the AcquaLink system or added to an existing NMEA 2000 network. In the AcquaLink system the gauges receive the data through the AcquaLink Nav Box. The gauges are daisy chained with VDO bus cables. Please refer to chapter “VDO Bus” and follow the installation rules and limitations.

When used in a NMEA 2000 system the gauges can display data present in the NMEA 2000 network. Please refer to the chapter “NMEA 2000” and follow the installation rules and limitations.

Components

In the box:

- 110mm gauge
- Square bezel
- Gasket
- Spinlock
- Silicone protection cover
- Installation instruction
- Mounting template

Available versions

A2C Number	Function
A2C59501900	Apparent wind angle gauge
A2C59501901	Apparent wind angle magnified gauge
A2C59501902	Apparent wind speed gauge
A2C59501903	Depth gauge 200m / 660 ft
A2C59501904	Depth gauge 660 ft / 200m
A2C59501905	Speed through water 12 knots
A2C59501906	Speed through water 50 knots
A2C59501907	Speed through water 35 mph / 60 kmh
A2C59501908	Speed over ground 12 knots
A2C59501909	Speed over ground 70 mph / 115 kmh
A2C59501910	Speed over ground 35 mph / 60 kmh
A2C59501911	Compass
A2C59501912	Rudder angle gauge 110 mm
A2C59501913	Tachometer 3000 rpm
A2C59501914	Tachometer 5000 rpm
A2C59501915	Tachometer 7000 rpm

VDO Bus

The VDO Bus is a proprietary CanBus system based on NMEA 2000. Heart of the VDO Bus AcquaLink system is the Nav Box. The Nav Box provides a wide range of digital and analogue input possibilities and distributes the received data to all gauges in the VDO Bus network. The VDO Bus uses M12 8 Pin cables and all devices are powered through the network.

The Nav Box has three VDO Bus ports, so three separate VDO Bus segments can be installed. This helps to reduce the power drop in the system and allows an easy installation in all areas of the vessel.

Every 110mm gauge has two equal VDO Bus connectors in the rear.

Important:

The VDO Bus network has to be terminated with **three** 120ohm terminators (included with the Nav Box)

You need to connect an 180Ohm terminator plug at the end of any VDO segment or not used Nav Box connector.



Note:

VDO Bus cables have two female connectors. In order to extent the cable length an optional gender changer connector is needed (A2C38805500)

VDO Bus Limitations

The Nav Box provides power to all the 110mm gauges and 4.3” TFTs connected to the system. Due to the power consumption and the resistance of the cables there are limitations of the maximum cable length and number of possible instruments in the system.

In order to have a properly working system the voltage drop of every of the three VDO Bus segments have to be calculated.

The load equivalency number (LEN) for the 110mm gauge is **4**.

1 LEN = 0.05 Ampere

LEN List for VDO Products:

Product	LEN
Nav Control	4
110mm gauge	4
4.3” TFT	12
52mm gauge	2

Calculation

12V power supply:

The voltage drop for every segment of the VDO Bus is calculated as follow:

Ohm's Law: E (voltage drop) = I (circuit current) x R (wire resistance)
 $R = 2/2x$ Cable Length (m) x Power Pair Resistance / 100
 $I = LEN$ (Load Equivalency Number) x 0.050 amps
 $L =$ Total length of VDO Bus cables on one segment

$$\rightarrow E = 0.05 \times LEN \times L \times 0.057$$

The voltage drop for each VDO Bus Segment shouldn't be higher than **3V**

Note: VDO BUS has 2x AWG 22 Power/Ground cables → different voltage drop calculation than NMEA 2000

24V power supply:

If using a 24V system the voltage drop may not be higher than **9V**

The NMEA Interface

The VDO 110mm gauges can be directly connected to a NMEA 2000 network without using the Nav Box system.

Note: If using the gauges with NMEA 2000 following limitations have to be exepcted:

- The gauges are not NMEA 2000 certified but compatible
- The illumination of the gauges is always ON
- As soon as the NMEA 2000 power is switched off the indication pointer will go back to the zero position
- The gauges will only read the NMEA 2000 PGNs listed below. No calibration is possible through the gauges
- When data is available from multiple sources, the gauge automatically selects the source with the lowest instance number

Please follow the general NMEA 2000 installation rules you can find at www.nmea.org.

110mm Gauges

Supported NMEA 2000 PGNs:

A2C Number	Description	NMEA2000 PGN	PGN Name	Note
A2C59501900	Apparent wind angle	130306	Wind Data	
A2C59501901	Apparent wind angle magnified	130306	Wind Data	
A2C59501902	Apparent wind speed	130306	Wind Data	
A2C59501911	Compass	127250	Vessel Heading	True
		127250	Vessel Heading	Magnetic
		127258	Magnetic Variation	
A2C59501903	Depth (meters)	128267	Water Depth	No offset
A2C59501904	Depth (feet)	128267	Water Depth	No offset
A2C59501908	Speed over ground (12kn)	129026	COG&SOG, Rapid Update	
A2C59501909	Speed over ground (70mph)	129026	COG&SOG, Rapid Update	
A2C59501910	Speed over ground (35mph)	129026	COG&SOG, Rapid Update	
A2C59501905	Speed through water (12kn)	128259	Speed; Water Preferred	
A2C59501906	Speed through water (50kn)	128259	Speed; Water Preferred	
A2C59501907	Speed through water (35mph)	128259	Speed; Water Preferred	
A2C59501913	RPM (3000)	127488	Engine Parameter, Rapid Update	
A2C59501914	RPM (5000)	127488	Engine Parameter, Rapid Update	
A2C59501915	RPM (7000)	127488	Engine Parameter, Rapid Update	
A2C59501912	Rudder angle	127245	Rudder	

Note: If more than one Tachometer is used in a NMEA 2000 network the gauges have to be preprogrammed using the AcquaLink Nav Box. With the Nav Box you can write instance numbers 0-3 to a gauge.

52mm Gauges

52mm gauges can only be connected directly to a 110mm Tachometer via an EasyLink daisy chain connection. Up to 16 satellite gauges can be connected to each tachometer.

The 52mm gauges are displaying the data distributed by the tachometer. The gauges can be used in a VDO or NMEA 2000 network.

Note: Engine instance can not be selected

Supported NMEA 2000 PGNs

A2C Number	Description	Supported PGN	PGN Function
A2C59501925	Engine trim position	127488	Engine Parameters, Rapid Update
A2C59501926	Engine oil temperature 52mm EasyLink (°C)	127489	Engine Parameters; Dynamic
A2C59501927	Engine oil temperature 52mm EasyLink (°F)	127489	Engine Parameters; Dynamic
A2C59501928	Fresh water level 52mm EasyLink	127505	Fluid Level
A2C59501929	Black water level 52mm EasyLink	127505	Fluid Level
A2C59501930	Fuel level 52mm EasyLink	127505	Fluid Level
A2C59501931	Coolant temperature 52mm EasyLink (°C)	127489	Engine Parameters; Dynamic
A2C59501932	Coolant temperature 52mm EasyLink (°F)	127489	Engine Parameters; Dynamic
A2C59501933	Exhaust gas temperature 52mm EasyLink (°C)	130316	Temperature, Extended Range
A2C59501934	Exhaust gas temperature 52mm EasyLink (°F)	130316	Temperature, Extended Range
A2C59501935	Engine oil pressure 52mm EasyLink (bar)	127489	Engine Parameters, Dynamic
A2C59501936	Engine oil pressure 52mm EasyLink (psi)	127489	Engine Parameters, Dynamic
A2C59501937	Transmission oil pressure 52mm EasyLink (bar)	127493	Transmission Parameters, Dynamic
A2C59501938	Transmission oil pressure 52mm EasyLink (psi)	127493	Transmission Parameters, Dynamic
A2C59501939	Rudder 52mm EasyLink	127245	Rudder
A2C59501940	Battery voltage 52mm EasyLink (12V)	127508	Battery Status

A2C59501941	Battery voltage 52mm EasyLink (24V)	127508	Battery Status
A2C59501942	Battery current 52mm EasyLink (60A)	127508	Battery Status
A2C59501943	Battery current 52mm EasyLink (150A)	127508	Battery Status
A2C59501944	Boost pressure 52mm EasyLink (bar)	127488	Engine Parameters, Rapid Update
A2C59501945	Boost pressure 52mm EasyLink (psi)	127488	Engine Parameters, Rapid Update

Installation of the VDO 110mm gauge

Before beginning, disconnect the negative terminal on the battery, otherwise you risk a short circuit. If the craft is supplied by auxiliary batteries, you must also disconnect the negative terminals on these batteries! Short circuits can cause fires, battery explosions and damages to other electronic systems. Please note that when you disconnect the battery, all volatile electronic memories lose their input values and must be reprogrammed.

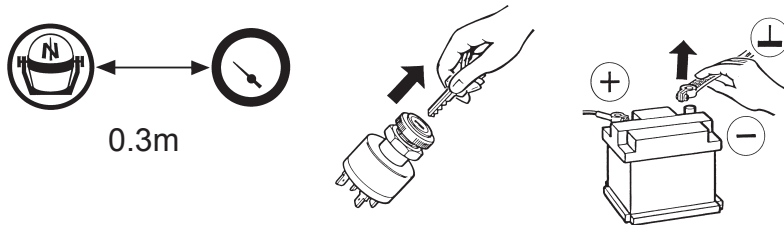

- Do not drill holes or ports in load-bearing or stabilizing stays or tie bars!
- Note the necessary clearance behind the drill hole or port at the installation location. Required mounting depth: 800 mm.
- Drill small ports; enlarge and complete them, if necessary, using taper milling tools, saber saws, keyhole saws or files. Debur edges. Follow the safety instructions of the tool manufacturer.

Note:

Please use the mounting template to determine the right hole size and mounting location

- Connect the Bus cables and terminators on the rear of the instrument, before fixing the unit to the panel

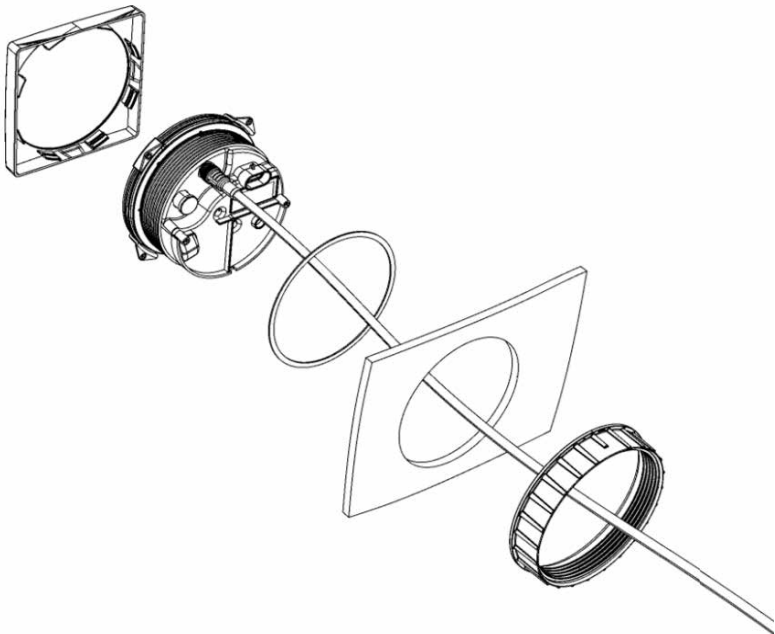
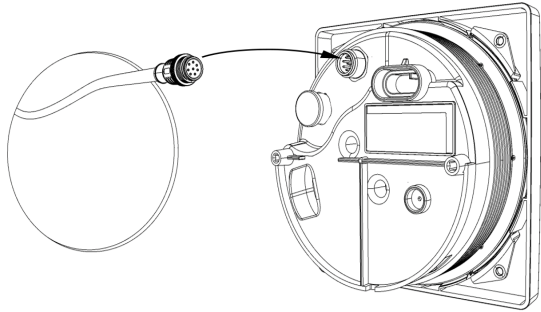

- Assemble the unit as shown in the diagram above

- Fix the gauge by turning the Spinlock in a clockwise direction and locking it hand tight

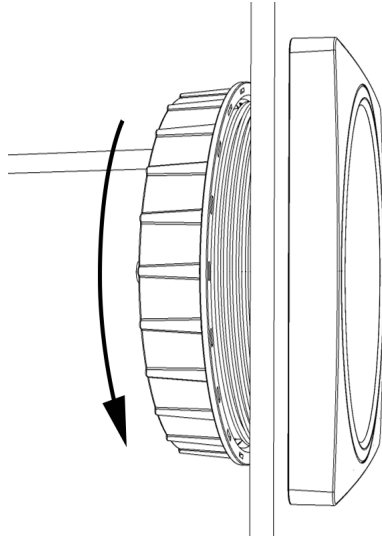

Hardware Specification

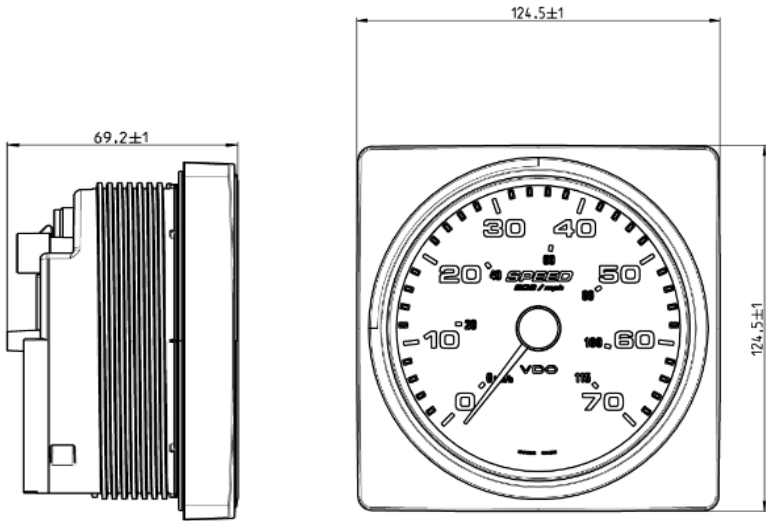

Connectors

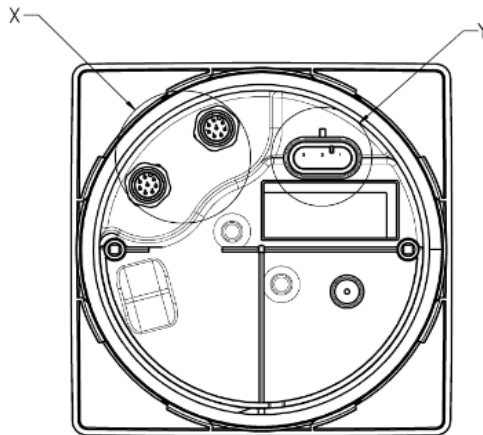

Note: Connector Y is only on all Tachometers

Pinout

Connector X: VDO Bus M12 Connectors



Pin	Signal
1	Ignition Kl. 15
2	GND Kl. 31
3	Battery+ Kl. 30
4	CAN H
5	CAN L
6	GND Kl. 31
7	Ignition Kl. 15
8	GND Kl. 31

Connector Y: EasyLink Superseal Connector (Only on Tachometers)

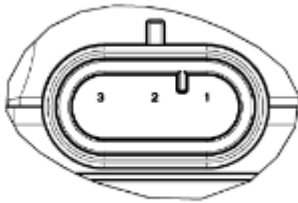

Pin	Signal
1	Power
2	GND
3	Data

Technical Data

Housing Material	PBT GB 20
Bezel Material	PC graphilgrey/ RAL 7021
Dimensions	WxHxD: 124.5 x 124.5 x 69.2 mm
Connectors	2x M12 8 Pin; 3 Pin Superseal on Tachometers
Operating temperature	-20° / +70°
Storage temperature	-40 / +85°
Operating voltage range	8 – 28 VDC
Current consumption	< 300mA
Protection Class	IP 67 According to IEC 60529:2001; in nominal position
EMC	DIN-EN 61000-6-2:2006 IEC 60945:2002 If used in a NMEA 2000 network: No load dump protection (ISO7637-2)
Approval	CE

Accessory

Packed A2C	Description
A2C96244600	VDO Bus Cable 0,5m
A2C96244900	VDO BUS VDO Bus to NMEA 2000
A2C38805700	VDO Bus Cable 2m
A2C38804900	Infield Installation Connector VDO BUS/ WIND
A2C99793900	Termination Resistor VDO BUS
A2C38805500	Gender Changer VDO BUS
A2C96243700	NMEA 2000 Cable 0,5m
A2C96243800	NMEA 2000 Cable 2m
A2C39308500	NMEA 2000 Infield Installation Connector Female
A2C39310500	NMEA 2000 Infield Installation Connector Male
A2C39312700	T Splitter NMEA 2000
A2C39310600	NMEA 2000 Terminator Female
A2C39311000	NMEA 2000 Terminator Male
A2C39312500	NMEA 2000 Inline Terminator
A2C39312900	NMEA 2000 Power cable
A2C59501963	Bezel 110
A2C59501969	Silicone cover for display 110
A2C59501946	VDO Bus Cable 5m
A2C59501947	VDO Bus Cable 10m
A2C59501948	NMEA 2000 Cable 6m
A2C59501949	NMEA 2000 Cable 10m
A2C59501950	NMEA 2000 Cable 30m



Continental Automotive Switzerland AG
Industriestrasse 18
9464 Rüthi
Switzerland

www.marine.vdo.com
VDO – A Trademark of the Continental Corporation

The information provided in this brochure contains only general descriptions or performance characteristics, which do not always apply as described in case of actual use or which may change as a result of further development of the products. This information is merely a technical description of the product. It is not meant or intended to be a special guarantee for a particular quality or particular durability. An obligation to provide the respective characteristics shall only exist if expressly agreed in the terms of contract. We reserve the right to make changes in availability as well as technical changes without prior notice.

A2C99833700 Continental Automotive Switzerland AG | English © 2016