

CE REV 002A

# Quick®

High Quality Nautical Equipment

## BOW THRUSTER

**BTQ110**

**BTQ125**

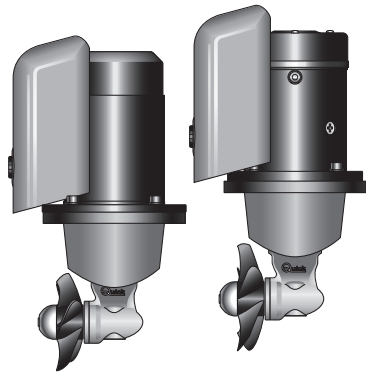

**IT** Manuale d'uso

**EN** User's Manual

ELICHE DI MANOVRA DI PRUA

BOW THRUSTERS



**IT****INDICE**

Pag. 4	<b>CARATTERISTICHE E INSTALLAZIONE</b> - requisiti per l'installazione - il tunnel
Pag. 5	<b>INSTALLAZIONE</b> - requisiti per l'installazione - il tunnel
Pag. 6	<b>INSTALLAZIONE</b> - requisiti per l'installazione - il tunnel
Pag. 7	<b>INSTALLAZIONE</b> - il thruster
Pag. 8	<b>INSTALLAZIONE</b> - il piede e la flangia di supporto motore
Pag. 9	<b>INSTALLAZIONE</b> - montaggio dell'elica
Pag. 10/11	<b>SCHEMA DI COLLEGAMENTO</b>
Pag. 12	<b>AVVERTENZE IMPORTANTI - USO</b>
Pag. 13/14	<b>MANUTENZIONE</b>
Pag. 15	<b>RICAMBI</b>

**EN****INDEX**

Pag. 16	<b>CHARACTERISTICS AND INSTALLATION</b> - installation requirements - the tunnel
Pag. 17	<b>INSTALLATION</b> - installation requirements - the tunnel
Pag. 18	<b>INSTALLATION</b> - installation requirements - the tunnel
Pag. 19	<b>INSTALLATION</b> - the thruster
Pag. 20	<b>INSTALLATION</b> - Gearleg and motor support flange
Pag. 21	<b>INSTALLATION</b> - propeller fitting
Pag. 22/23	<b>CONNECTION DIAGRAM</b>
Pag. 24	<b>WARNING - USAGE</b>
Pag. 25/26	<b>MAINTENANCE</b>
Pag. 27	<b>SPARE PARTS</b>



**PRIMA DI UTILIZZARE IL BOW THRUSTER LEGGERE ATTENTAMENTE IL PRESENTE MANUALE D'USO. IN CASO DI DUBBI CONSULTARE IL RIVENDITORE QUICK®.**

**ATTENZIONE:** i Bow Thruster Quick® sono stati progettati e realizzati per asservire all'uso nautico.

- ⚠ Non utilizzare questi apparecchi per altri tipi di applicazioni.
- ⚠ Quick® non si assume alcuna responsabilità per i danni diretti o indiretti causati da un uso improprio dell'apparecchio o da una scorretta installazione.
- ⚠ Il Bow thruster non è progettato per mantenere carichi generati in particolari condizioni atmosferiche (burrasca).
- ⚠ Si raccomanda di affidare a un professionista la predisposizione e il posizionamento del tubo allo scafo. Queste istruzioni sono generiche, e non illustrano in alcun modo i dettagli delle operazioni di predisposizione del tunnel quale competenza del cantiere. In caso di eventuali problemi provocati da un'installazione difettosa del tunnel, ne risponderà in pieno l'installatore.
- ⚠ Non installare il motore elettrico nelle vicinanze di oggetti facilmente infiammabili.

**LA CONFEZIONE CONTIENE:** bow thruster - dima di foratura - guarnizione - o-ring (per l'assemblaggio) - manuale di istruzioni - condizioni di garanzia.

#### ATTREZZI NECESSARI PER L'INSTALLAZIONE:

**BTQ110**, trapano con punta da Ø 6 mm (15/64"); tazza Ø 25 mm (1"); chiavi maschio esagonale: 4 mm, 5 mm, 6 mm; chiave a forchetta o poligonale: 10 mm.

**BTQ125**, trapano con punta da Ø 6 mm (15/64"); tazza Ø 25 mm (1"); chiavi maschio esagonale: 4 mm, 5 mm, 6 mm; chiave a forchetta o poligonale: 10 mm.

**ACCESSORI QUICK® CONSIGLIATI:** TCD 1022 - TCD 1042 - TCD1044 - TCD1062 - TMS - TSC - PSS - TFH3

MODELLO	BTQ1102512	BTQ1253012	BTQ1254012
Tipo elica	singola		
Tunnel Ø	110 mm (4" 21/64)	125 mm (5")	125 mm (5")
Potenza motore	1,3 Kw	1,5 Kw	2,2 KW
Tensione	12 V	12 V	12 V
Sezione cavi	35 mm <sup>2</sup> (AWG 2)	50 mm <sup>2</sup> (AWG 1)	95 mm <sup>2</sup> (AWG 3/0)
Fusibile	130 A CNL DIN	225 A CNL DIN	325 A CNL DIN
Spinta	25 kgf (55.1 lb)	30 kgf (66.1 lb)	40 kgf (88.2 lb)
Peso	9,0 kg (19.8 lb)	10,0 kg (22.0 lb)	10,8 kg (23.8 lb)
Spessori limite dei tubi	min. 3 mm - max 7 mm (min. 1/8" - max 9/32")		



Quick® si riserva il diritto di apportare modifiche alle caratteristiche tecniche dell'apparecchio e al contenuto di questo manuale senza alcun preavviso. In caso di discordanze o eventuali errori tra il testo tradotto e quello originario in italiano, fare riferimento al testo italiano o inglese.



## REQUISITI PER L'INSTALLAZIONE

### IL TUNNEL

- La posizione del tunnel dipenderà dalla forma interna ed esterna della prua della imbarcazione.
- La sistemazione ottimale del tunnel, sarà più a prua e più a fondo possibile, minimo 0,75 volte il diametro del tunnel dalla linea di galleggiamento.

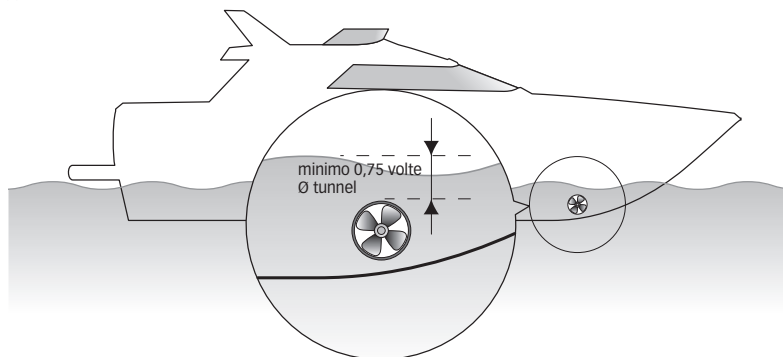

- Per evitare fenomeni di cavitazione nell'elica, si dovrà posizionare il tunnel più a fondo possibile.
- L'effetto di leva nell'imbarcazione è proporzionale all'aumento della distanza (L1 e L2) che si rileva, tra il baricentro e la posizione del tunnel A e B.

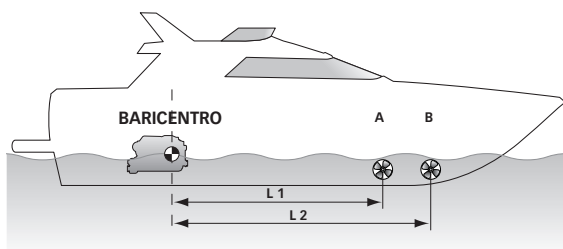

 Per avere maggiore effetto leva preferire la posizione B alla posizione A.

- L'aumento della lunghezza del tunnel aumenta l'effetto delle perdite di carico diminuendo la forza nominale di propulsione.
- Per limitare le perdite di carico, la lunghezza consigliata è pari a 3-4 volte il diametro del tubo; è tollerato un rapporto fino a 6 volte il diametro.

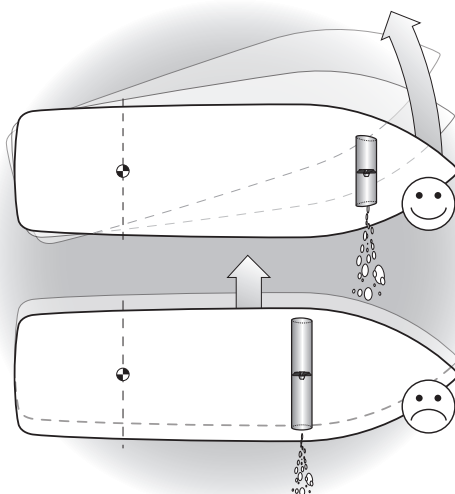



- Le estremità arrotondate del tunnel limitano l'innesco di turbolenze e cavitazione, migliorando le prestazioni della spinta dell'elica e riducendo al minimo la rumorosità.

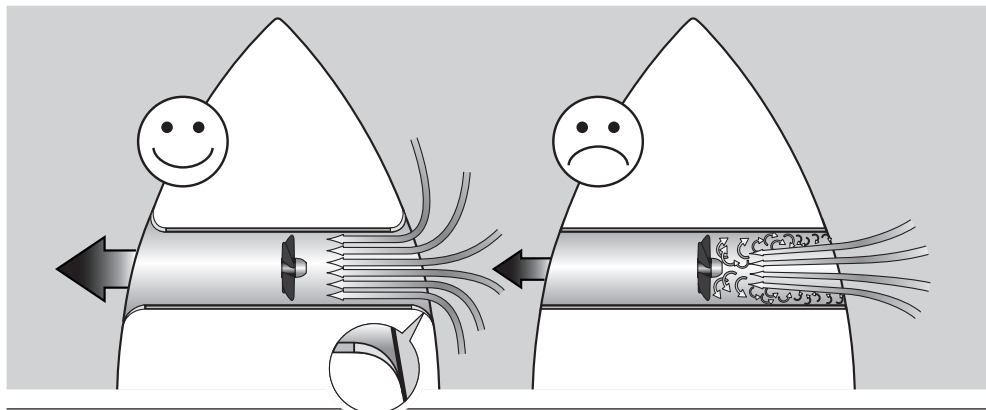

- Quando l'imbarcazione è in movimento, la forza prodotta dal flusso dell'acqua produce della resistenza sulla faccia posteriore del tunnel, che diventa un'area piatta al flusso dell'acqua. Per limitare questo fenomeno, prevedere una rientranza nella parte posteriore del tunnel. Questa dipenderà dalla sagoma dello scafo dell'imbarcazione, o in alternativa, realizzare un deflettore nella parte anteriore del tunnel.

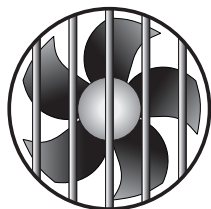
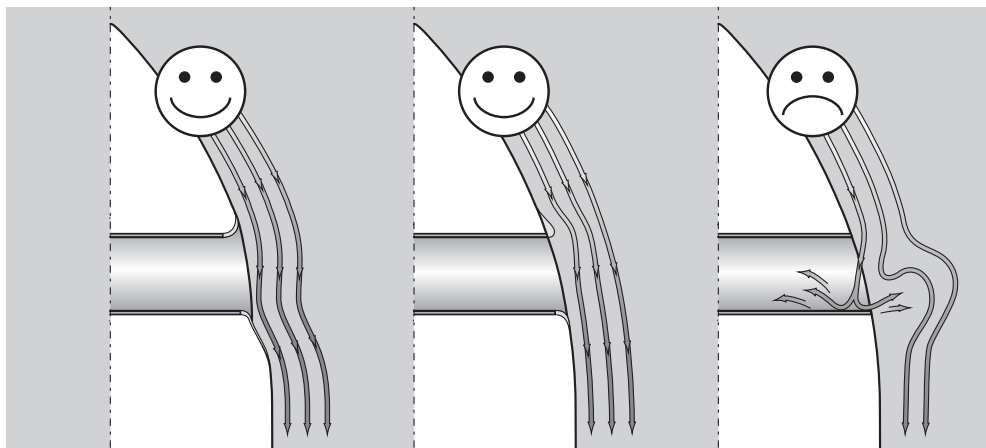

- Nel caso in cui il tunnel sia vicino alla linea di galleggiamento è consigliabile prevedere l'inserimento di una grata all'estremità del tubo. La grata deve avere maglie verticali e più larghe possibili, per non contrastare la spinta dell'elica. Le maglie verticali impediscono l'ingresso della maggior parte degli oggetti galleggianti.



## IL THRUSTER

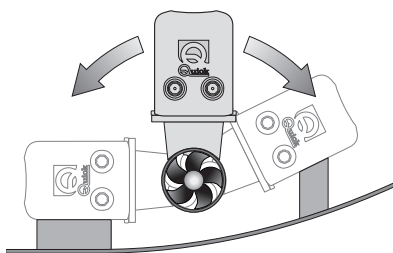

- Il thruster può essere installato con qualunque angolo all'interno di 90° dalla verticale.
- Se il motore elettrico è posizionato per necessità con un angolo superiore a 30° rispetto alla verticale, si rende necessario la realizzazione in opera di un apposito sostegno.

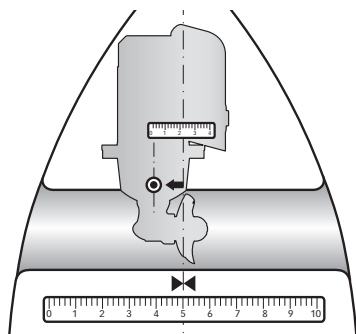

- Per posizionare il thruster nel tubo trovare la mezzeria del tubo e spostarsi del valore dato (**a destra o a sinistra vedi NOTA a pag.11**) nello schema sottostante affinché l'elica si posizioni nell'esatta metà della lunghezza interna del tunnel.

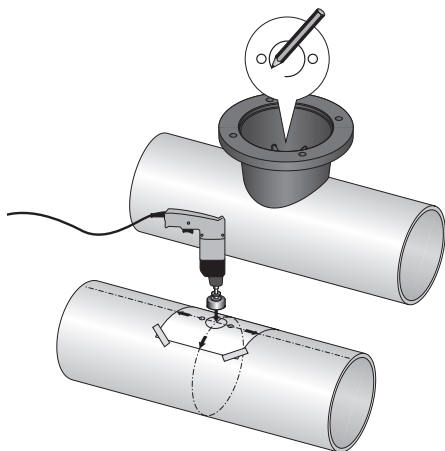
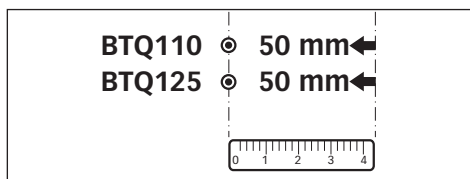

- Utilizzare la flangia per contrassegnare sul tubo il centro dei fori.

- Fissare la dima di foratura sui riferimenti accertandosi che siano allineati con precisione alla mezzeria del tubo. N.B. Tutti i fori devono essere allineati con precisione alla mezzeria del tunnel, in quanto la tolleranza tra l'elica ed i tunnel è minima.

- Fare attenzione che non vi siano residui di resina nella parte di contatto fra la flangia e il tubo; ciò potrebbe causare disallineamenti. E' necessario asportare con carta vetrata eventuali residui di resina e di tutti gli eventuali impedimenti al corretto contatto.

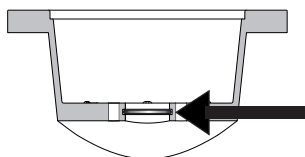

- Inserire un o-ring nella specifica sede all'interno della flangia.



## IL PIEDE RIDUTTORE E LA FLANGIA DI SUPPORTO MOTORE

- Procedere al montaggio del piede riduttore con la specifica guarnizione di tenuta.

- Come ulteriore precauzione contro l'ingresso d'acqua, applicare silicone per uso nautico nella zona di contatto tra flangia e tubo.

- Fissare il tutto con la flangia utilizzando le specifiche viti e rondelle.

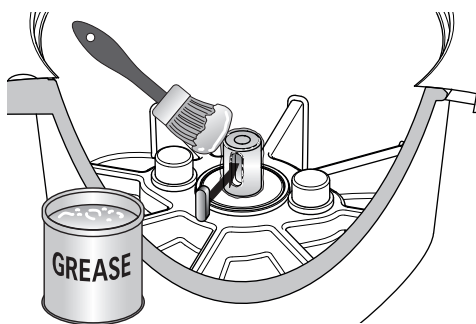
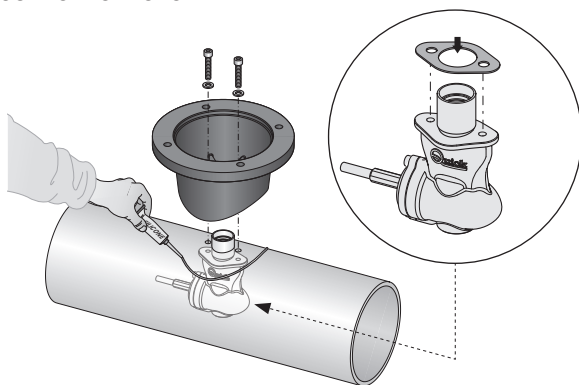

- Ingrassare la parte terminale dell'albero del piede riduttore; montare la chiavetta nella propria sede.

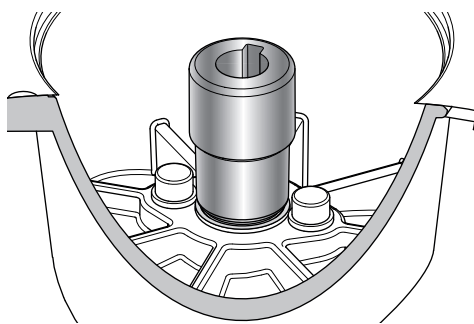

- Inserire il giunto elastico nella parte terminale dell'albero del piede riduttore.

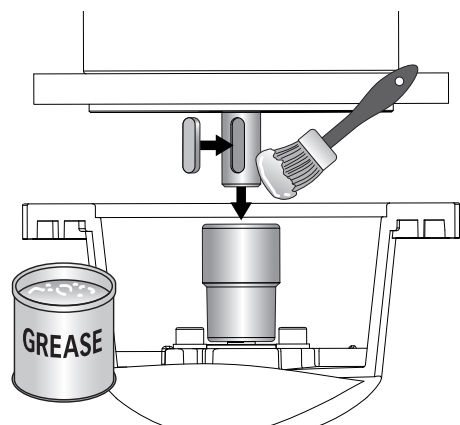

- Ingrassare la parte terminale dell'albero motore; montare la chiavetta nella propria sede.

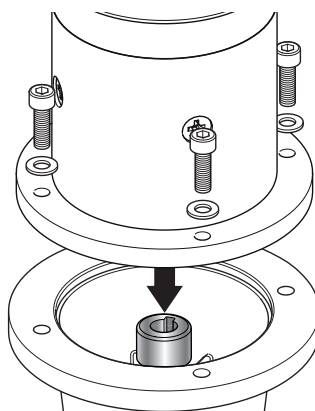

- Inserire il motore sul giunto elastico, fissare con le 4 viti e rondelle in dotazione.





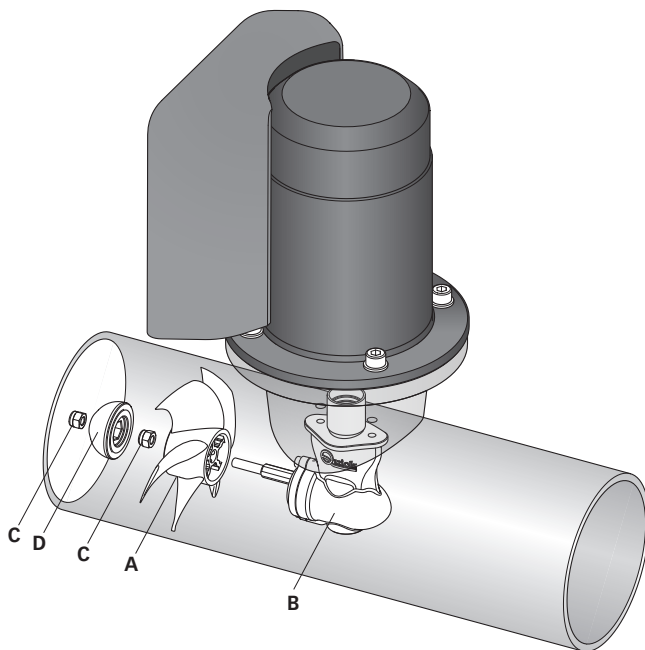

## L'ELICA

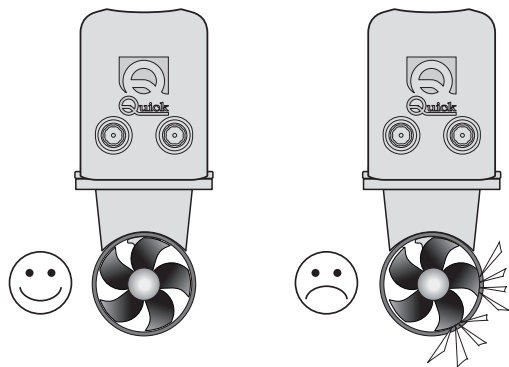

### MONTAGGIO DELL'ELICA

Inserire l'elica **A** sull'albero del piede riduttore **B**, fissare l'elica con il dado autofrenante **C**, inserire l'anodo **D** e bloccarlo con l'altro dado autofrenante **C**.



 **ATTENZIONE:** accertarsi, ad assemblaggio ultimato, che l'elica sia ben centrata all'interno del tunnel.

### PANNELLO DI COMANDO

Per l'installazione del pannello di comando, fare riferimento ai manuali d'uso "TCD 1022 - TCD 1042 - TCD 1044".



## SISTEMA BASE BTQ110

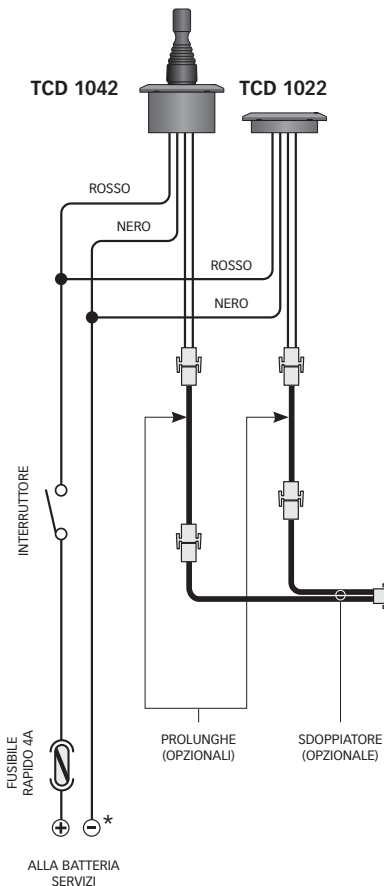

## ACCESSORI QUICK® PER L'AZIONAMENTO DELL'ELICA DI MANOVRA

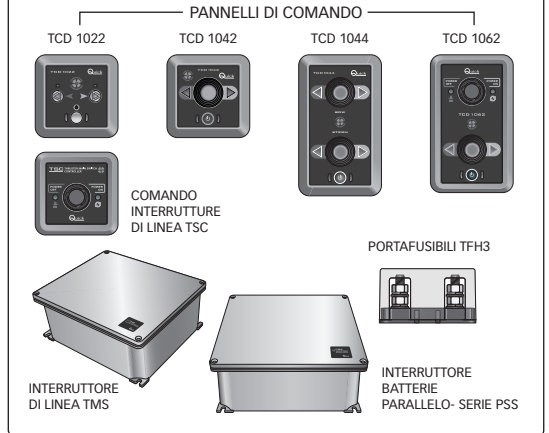

\* NEGATIVO DEI GRUPPI BATTERIA IN COMUNE.

\*\* **ATTENZIONE:** IN CASO DI SOVRATEMPERATURA LA PROTEZIONE TERMICA SUL MOTORE SI APRIRÀ E INTERROMPERÀ IL CONTATTO NEGATIVO SUL TERLUTTORE. ATTENDERE IL TEMPO NECESSARIO ALLA RIATTIVAZIONE.



## SISTEMA BASE BTQ125

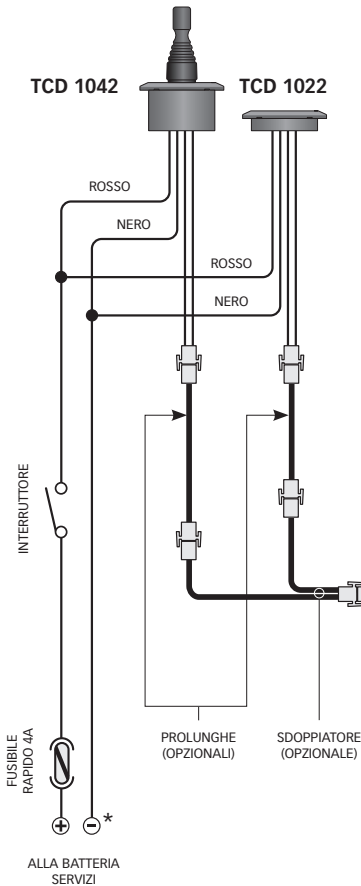

## ACCESSORI QUICK® PER L'AZIONAMENTO DELL'ELICA DI MANOVRA

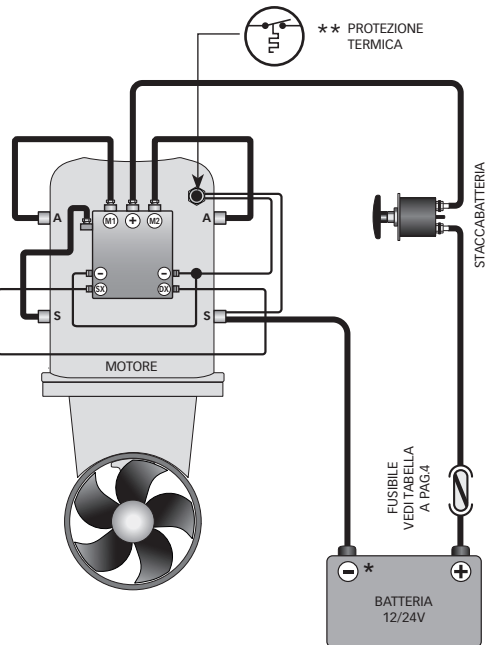
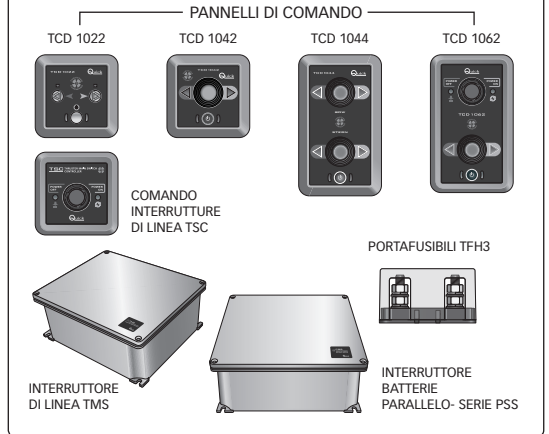





\* NEGATIVO DEI GRUPPI BATTERIA IN COMUNE.

\*\* **ATTENZIONE:** IN CASO DI SOVRATEMPERATURA LA PROTEZIONE TERMICA SUL MOTORE SI APRIRÀ E INTERROMPERÀ IL CONTATTO NEGATIVO SUL Teleruttore. ATTENDERE IL TEMPO NECESSARIO ALLA RIATTIVAZIONE.



## AVVERTENZE IMPORTANTI

- 
**ATTENZIONE:** questo bow thruster non è realizzato per un funzionamento continuo. E' provvisto di protezioni che ne limitano il funzionamento fino ad un tempo massimo, come riportato sul manuale dei comandi. E' assolutamente vietato bypassare, o modificare tali protezioni per aumentare il tempo di funzionamento, pena la decadenza della garanzia e di qualsiasi responsabilità da parte di Quick SPA.
- 
**ATTENZIONE:** accertarsi che non vi siano bagnanti ed oggetti galleggianti nelle vicinanze, prima d'avviare il thruster.
- 
**ATTENZIONE:** non deve essere presente materiale infiammabile nel gavone o nella zona in cui sia presente il motore del bow thruster.
- 
**ATTENZIONE:** non utilizzare il bow thruster fuori dall'acqua per un tempo superiore a 10 secondi.
- 
**ATTENZIONE:** durante l'ormeggio, si raccomanda di non lasciare cime libere in acqua che potrebbero essere risucchiate dalle eliche causandone la rottura.

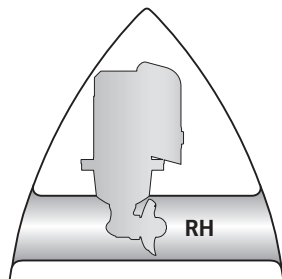
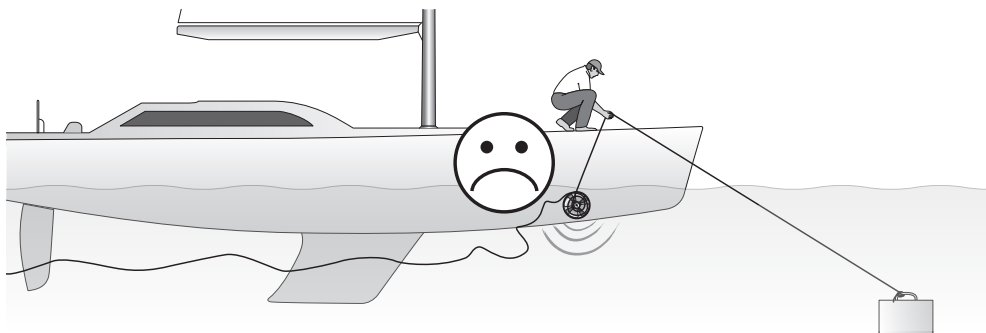

 **NOTA:** il bow thruster va installato con l'elica a destra del piede riduttore (vedi figura).

Se fosse necessario installare il bow thruster nella posizione opposta, bisognerà invertire il collegamento dei due cavi (blu e grigio) del cavo comando sul teleinvertitore.

## USO DELL'ELICA DI MANOVRA

### ACCENSIONE

L'accensione avviene in conseguenza all'attivazione di un pannello TCD. Per l'uso dell'elica fare riferimento al manuale del comando TCD.



I Thruster Quick® sono costituiti da materiale resistenti all'ambiente marino: è indispensabile, in ogni caso, rimuovere periodicamente i depositi di sale che si formano sulle superfici esterne per evitare corrosioni e di conseguenza inefficienza del sistema.



**ATTENZIONE:** accertarsi che non sia presente l'alimentazione al motore elettrico quando si eseguono le operazioni di manutenzione.

Smontare una volta all'anno, seguendo i seguenti punti:

- Pulire elica (30), tunnel e piede riduttore (19).
- Sostituire l'anodo (32) (effettuare più frequentemente se necessario).
- Sostituire l'elica se danneggiata o usurata.
- Controllare il serraggio di tutte le viti.
- Accertarsi che non vi siano infiltrazioni di acqua all'interno.
- Verificare che tutte le connessioni elettriche siano ben fissate e prive di ossido.
- Verificare che le batterie siano in buone condizioni.



**ATTENZIONE:** non verniciare l'anodo (32), le sigillature e l'albero del piede riduttore dove alloggia l'elica.

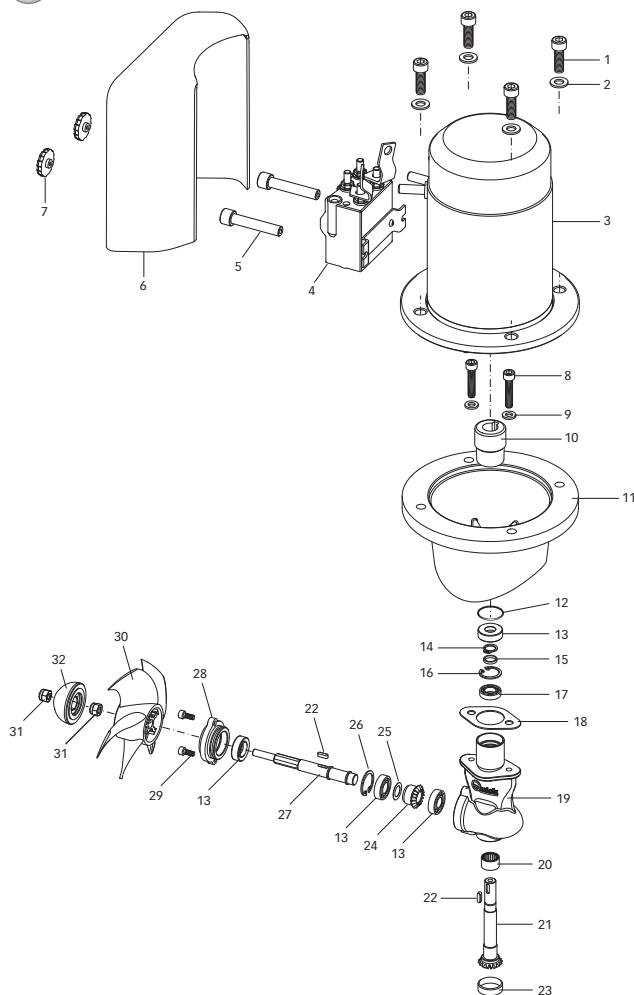

## BTQ 1102512

POS.	DENOMINAZIONE
1	VITE FISSAGGIO MOTORE
2	RONDELLA FISSAGGIO MOTORE
3	MOTORE 1,3KW 12V
4	CASSETTA TELEINVERTITORI T6411-12
5	DISTANZIALE CARTER A
6	CARTER CASSETTA TELEINVERTITORI
7	FISSAGGIO CARTER CASSETTA TELEINVERTITORI
8	VITE FISSAGGIO RIDUTTORE
9	RONDELLA
10	GIUNTO ELICA
11	FLANGIA MOTORE
12	O-RING
13	PARAOILIO
14	ANELLO ELASTICO ESTERNO
15	DISTANZIALE ALBERO
16	ANELLO ELASTICO INTERNO
17	CUSCINETTO
18	GUARNIZIONE RIDUTTORE
19	RIDUTTORE
20	CUSCINETTO
21	ALBERO COPPIA CONICA
22	CHIAVETTA
23	PARAOILIO
24	CORONA COPPIA CONICA
25	RASAMENTO
26	ANELLO ELASTICO INTERNO
27	ALBERO USCITA RIDUTTORE
28	FLANGIA RIDUTTORE
29	VITE
30	ELICA
31	DADO AUTOFRENANTE
32	ANODO



**ATTENZIONE:** accertarsi che non sia presente l'alimentazione al motore elettrico quando si eseguono le operazioni di manutenzione.

Smontare una volta all'anno, seguendo i seguenti punti:

- Pulire elica (31), tunnel e piede riduttore (20).
- Sostituire l'anodo (33) (effettuare più frequentemente se necessario).
- Sostituire l'elica se danneggiata o usurata.
- Controllare il serraggio di tutte le viti.
- Accertarsi che non vi siano infiltrazioni di acqua all'interno.
- Verificare che tutte le connessioni elettriche siano ben fissate e prive di ossido.
- Verificare che le batterie siano in buone condizioni.

**ATTENZIONE:** non verniciare l'anodo (33), le sigillature e l'albero del piede riduttore dove alloggia l'elica.

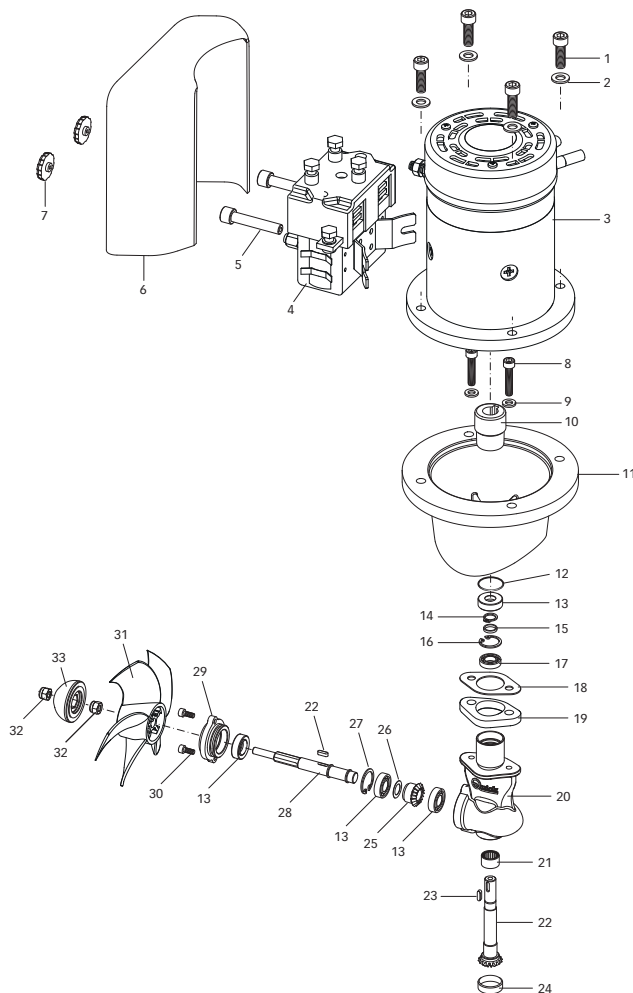

### BTQ 1253012 BTQ 1254012

POS.	DENOMINAZIONE
1	VITE FISSAGGIO MOTORE
2	RONDELLA FISSAGGIO MOTORE
3A	MOTORE 1,5KW 12V
3B	MOTORE 2,2 KW 12V
4	CASSETTA TELEINVERTITORI 150A 12V
5	DISTANZIALE CARTER A
6	CARTER CASSETTA TELEINVERTITORI
7	FISSAGGIO CARTER CASSETTA TELEINVERTITORI
8	VITE FISSAGGIO RIDUTTORE
9	RONDELLA
10	GIUNTO ELICA
11	FLANGIA MOTORE
12	O-RING
13	PARAOLIO
14	ANELLO ELASTICO ESTERNO
15	DISTANZIALE ALBERO
16	ANELLO ELASTICO INTERNO
17	CUSCINETTO
18	GUARNIZIONE RIDUTTORE
19	DISTANZIALE
20	RIDUTTORE
21	CUSCINETTO
22	ALBERO COPPIA CONICA
23	CHIAVETTA
24	PARAOLIO
25	CORONA COPPIA CONICA
26	RASAMENTO
27	ANELLO ELASTICO INTERNO
28	ALBERO USCITA RIDUTTORE
29	FLANGIA RIDUTTORE
30	VITE
31	ELICA
32	DADO AUTOFRENANTE
33	ANODO

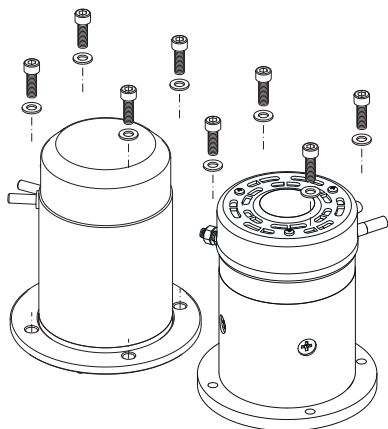

OSP MOT 1300W 12V BTQ110-140+T  
OSP MOT 1500W 12V BTQ125-140+T  
OSP MOT 2200W 12V BTQ125-140+T

FVEMFEL13121400  
FVEMFEL15121400  
FVEMFEL22121400

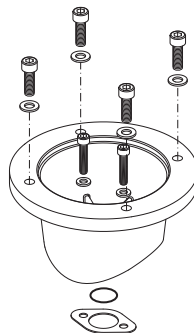

OSP KIT FLANGIA ELICA BTQ110-125

FVSGFLBTQ110A00

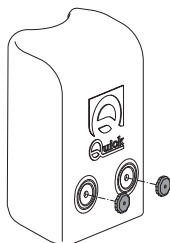

OSP KIT CARTER 'A' BTQ

FVSGCARTABTQA00



OSP KIT RIDUTTORE BTQ110  
OSP KIT RIDUTTORE BTQ125

FVSGGGBT1100A00  
FVSGGGBT1250A00

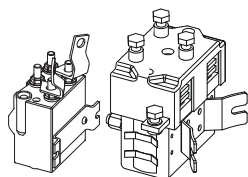

OSP KIT CASSETTA TELEINV T6411-12 BTQ  
OSP KIT CASSETTA TELEINV 150A 12V

FVST64111200A00  
FVSGRCT15012A00

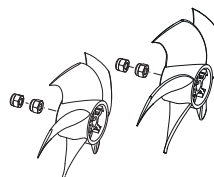

OSP KIT ELICA D110  
OSP KIT ELICA D125

FVSGEL110000A00  
FVSGEL125000A00



OSP KIT GIUNTO BTQ 110-125

FVSGG1101250A00



OSP KIT ANODO ELICA BTQ110-125

FVSGANBTQ110A00



**BEFORE USING THE BOW THRUSTER, READ THIS INSTRUCTION MANUAL CAREFULLY.  
IF IN DOUBT, CONTACT YOUR NEAREST QUICK® DEALER.**

**WARNING:** Quick® Bow Thrusters have been designed and constructed only for nautical use.

- ⚠ Do not use these appliances for other uses.
- ⚠ Quick® shall accept no responsibility for direct or indirect damages caused by improper use of the appliance or an improper installation.
- ⚠ The Bow Thruster is not designed to maintain loads generated in particular atmospheric conditions (storms).
- ⚠ We recommend you entrust preparation and positioning of the tube on the hull to a skilled professional. These are generic instructions and do not give details of the preparatory operations for installing the tunnel, since this is the competence of the boatyard. The installer shall bear full responsibility for any problems caused by defective installation of the tunnel.
- ⚠ Do not install the electric motor near easily inflammable objects.

**THE PACKAGE CONTAINS:** bow thruster - drill template - gasket - o-ring (for assembly) - user's manual - conditions of warranty.

**TOOLS REQUIRED FOR INSTALLATION:**

**BTQ110**, drill and drill bits Ø 6 mm (15/64"); hollow mill Ø 25 mm (1"); hexagonal male key: 4 mm, 5 mm, 6 mm; fork or polygonal key: 10 mm.

**BTQ125**, drill and drill bits Ø 6 mm (15/64"); hollow mill Ø 25 mm (1"); hexagonal male key: 4 mm, 5 mm, 6 mm; fork or polygonal key: 10 mm.

**QUICK® ACCESSORIES RECOMMENDED:** TCD 1022 - TCD 1042 - TCD1044 - TCD1062 - TMS - TSC - PSS - TFH3

MODEL	BTQ1102512	BTQ1253012	BTQ1254012
N° Propellers	single		
Tunnel Ø	110 mm (4" 21/64)	125 mm (5")	125 mm (5")
Motor Power	1,3 Kw	1,5 Kw	2,2 KW
Voltage	12 V	12 V	12 V
Section of wire	35 mm <sup>2</sup> (AWG 2)	50 mm <sup>2</sup> (AWG 1)	95 mm <sup>2</sup> (AWG 3/0)
Fuse	130 A CNL DIN	225 A CNL DIN	325 A CNL DIN
Thrust	25 kgf (55.1 lb)	30 kgf (66.1 lb)	40 kgf (88.2 lb)
Weight	9,0 kg (19.8 lb)	10,0 kg (22.0 lb)	10,8 kg (23.8 lb)
Limit thickness values of the tubes	min. 3 mm - max 7 mm (min. 1/8" - max 9/32")		



Quick® reserves the right to introduce changes to the equipment and the contents of this manual without prior notice.  
In case of discordance or errors in translation between the translated version and the original text in the Italian language, reference will be made to the Italian or English text.





## INSTALLATION REQUISITES:

### THE TUNNEL

- The position of the tunnel will depend on the interior and exterior shape of the boats bow.
- Optimal positioning of the tunnel will be in the bow and as low as possible, at least 0.75 times the tunnel diameter from the waterline.

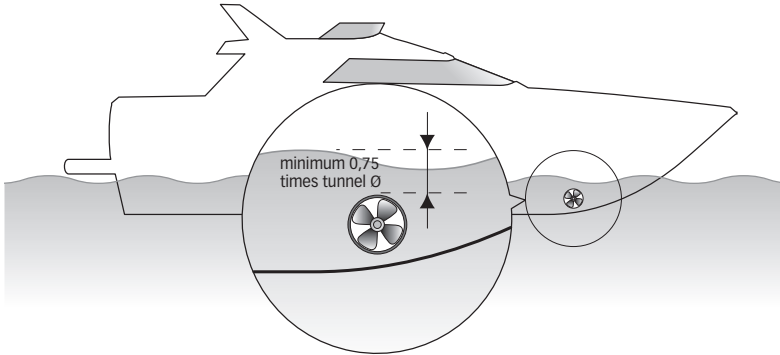

- To avoid cavitation in the propeller, the tunnel must be positioned as low as possible.
- The lever effect in the boat is proportional to the increase of the distance (L1 and L2) between the barycentre and the position of the tunnel A and B.

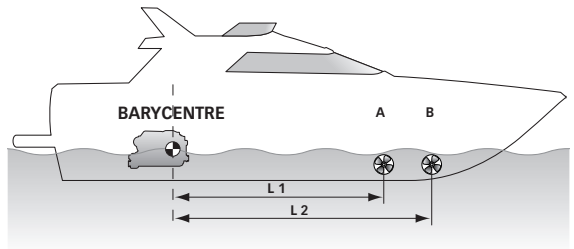

☞ For greater lever effect prefer position B to position A.

- An increase in the length of the tunnel increases the effect of the loss of charge, decreasing the nominal driving force.
- To limit losing charge, the optimal length is equal to 3-4 times the tube diameter; a ratio of up to 6 can be tolerated.

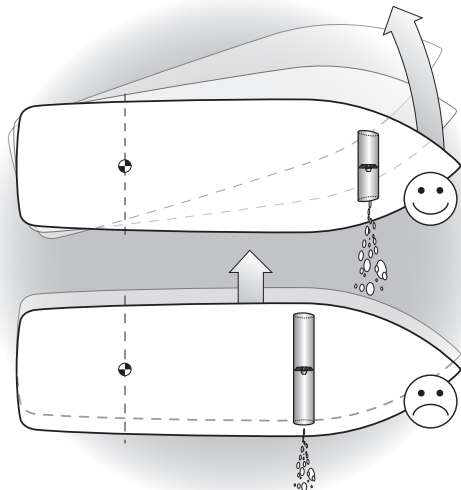



- The rounded ends of the tunnel limit the creation of turbulences and cavitations, improving performance of the propeller thrust and reducing noise levels to a minimum.

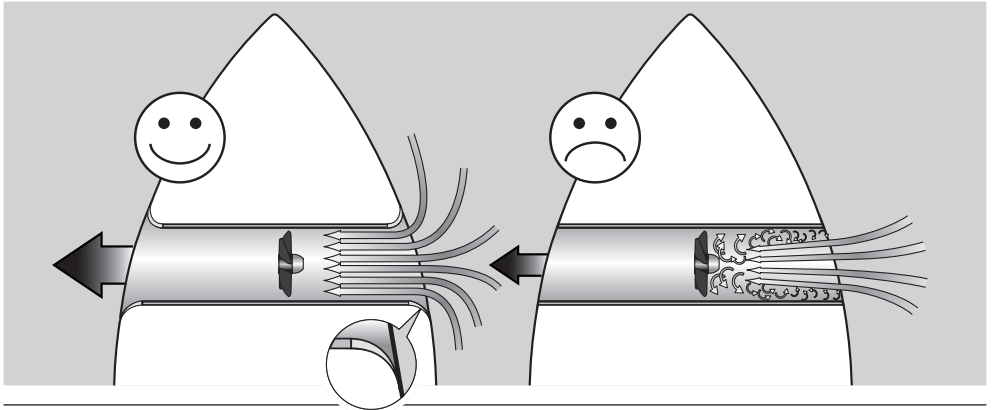

- The force produced by the flow of the water when the boat is moving produces resistance on the rear face of the tunnel, which is an area exposed frontally to the water flow. To limit this phenomenon, prepare an indentation in the rear part of the tunnel. Otherwise, create a deflector on the front part of the tunnel.

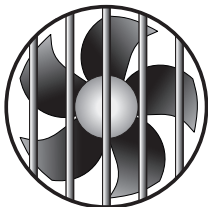
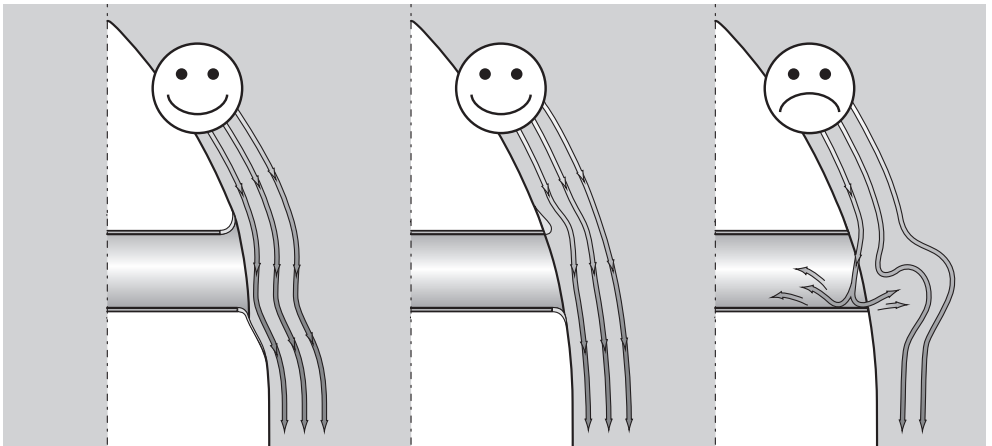

- If the tunnel is near the waterline, it is advisable to fit a grating at the end of the tube. The grating must have as large a vertical mesh as possible to avoid contrasting the propeller thrust. The vertical mesh prevents the entry of most of the floating objects.



## THE THRUSTER

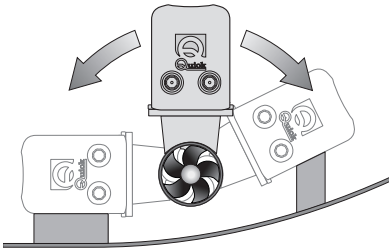

- The thruster can be installed at any angle within 90° from vertical.
- If the electric motor is positioned of necessity at an angle of more than 30° from vertical, a special support must be constructed.

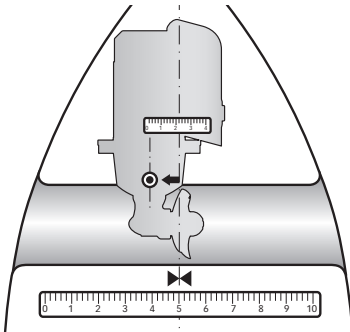

To position the thruster in the tube, find the half-way point and move to the value shown (**to the right or to the left**. See **NOTE page 11**) in the table below so that the propeller is positioned exactly half way along the internal length of the tunnel.

BTQ110	⊙	50 mm	←
BTQ125	⊙	50 mm	←

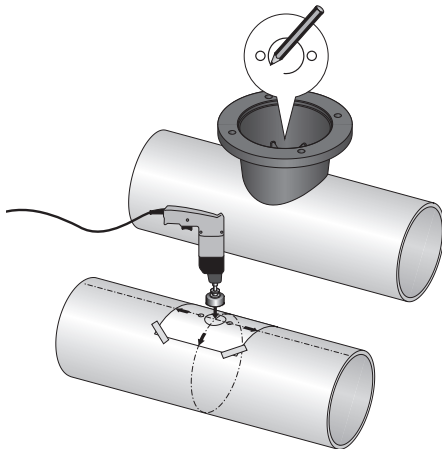
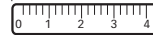

- Use the flange to mark the centre of the holes on the tube.
- Fix the drilling template on the reference points, making sure they are aligned with precision at the half-way point of the tube.  
N.B. All holes must be exactly aligned with the half-way point of the tunnel, since tolerance between propeller and tunnel is minimal.
- Take care that there are no resin residues in the contact area between flange and tube; this could cause misalignment. Any resin residues and any other hindrance to correct contact must be removed by sandpaper.

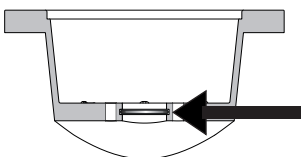

- Insert one o-ring into the special seat inside the flange.



## GEARLEG AND MOTOR SUPPORT FLANGE

- Proceed with fitting the gearleg with the special seal gasket.
- For further protection against the entry of water, apply silicone for nautical use around the point of contact between flange and tube.
- Fasten everything to the flange using the special screws and washers.

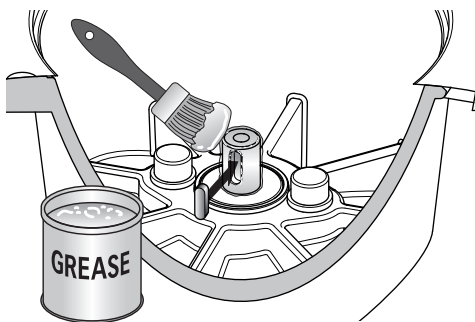
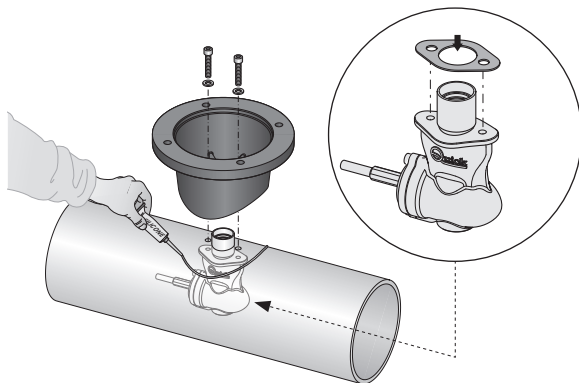

- Grease the terminal part of the gearleg shaft; fit the small key into its seat.

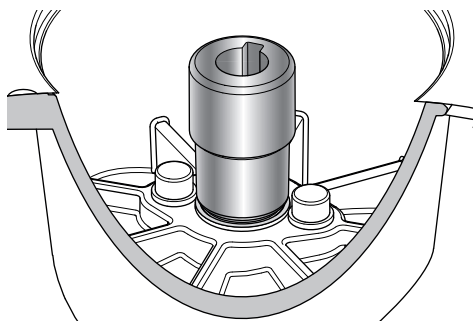

- Insert the elastic joint in the terminal part of the gearleg shaft.

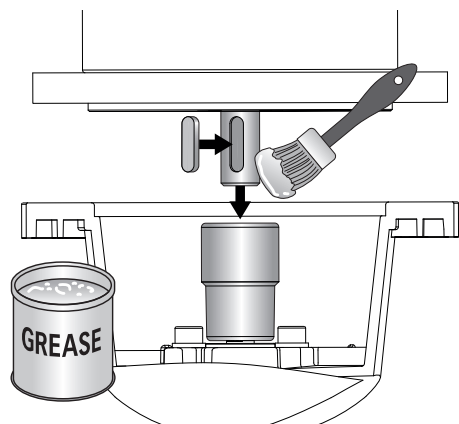

- Grease the terminal part of the gearleg shaft; fit the small key into its seat.

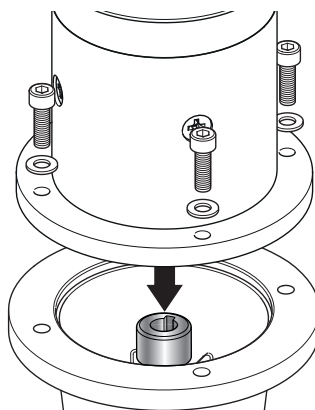

- Insert the motor onto the elastic joint; fasten it with the 4 screws and washers provided.



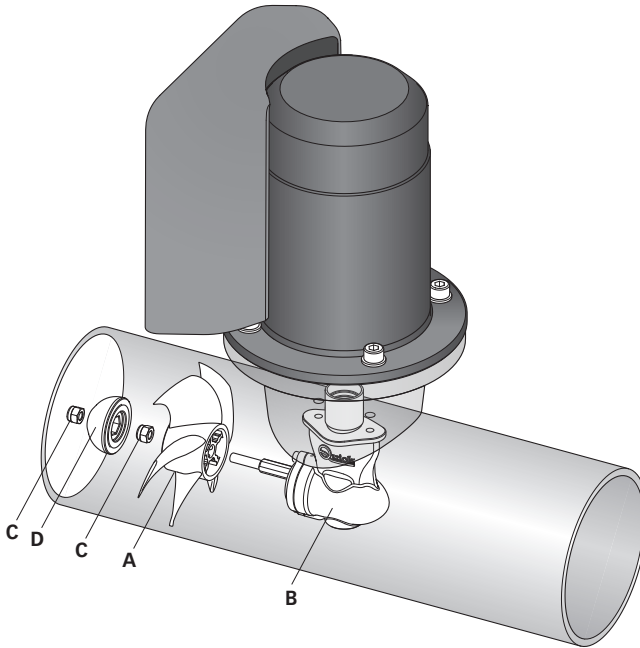

## PROPELLER

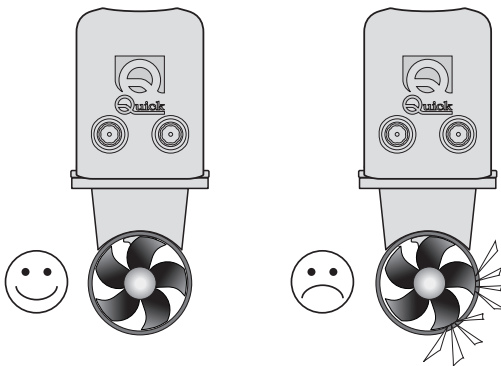

### PROPELLER FITTING

Insert the propeller **A** in the gear leg **B**, fix the propeller with the self-locking nut **C**, insert anode **D** and lock it with the other self-locking nut **C**.



 **WARNING:** on conclusion of assembly, make sure that the propeller is exactly positioned at the central point of the tunnel.

### CONTROL PANEL

To install the control panel, consult the "TCD 1022 - TCD 10422 - TCD 1044" instruction manuals.



## BASIC SYSTEM BTQ110

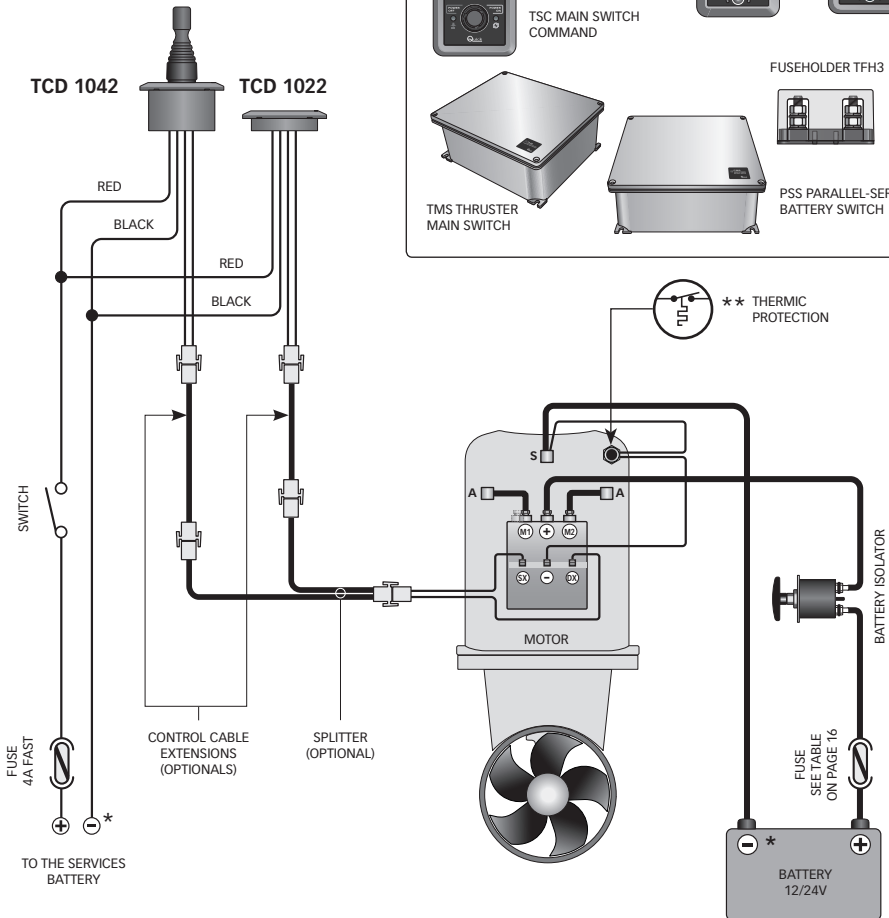

\* COMMON NEGATIVE FOR THE BATTERY GROUPS.

\*\* **WARNING:** IN CASE OF OVERTEMPERATURE, THE THERMAL PROTECTION ON THE MOTOR WILL OPEN AND INTERRUPT THE NEGATIVE CONTACT ON THE SOLENOID UNIT. WAIT AS LONG AS THE SYSTEM NEEDS TO REACTIVATE.



## BASIC SYSTEM BTQ125

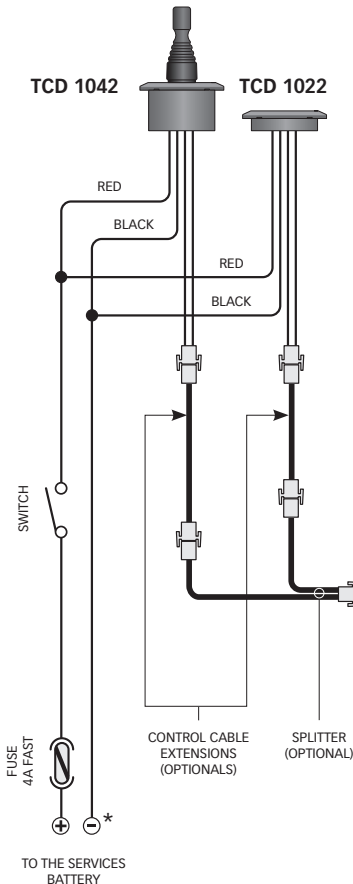

## QUICK® ACCESSORIES FOR ACTIVATION OF THE BOW THRUSTER

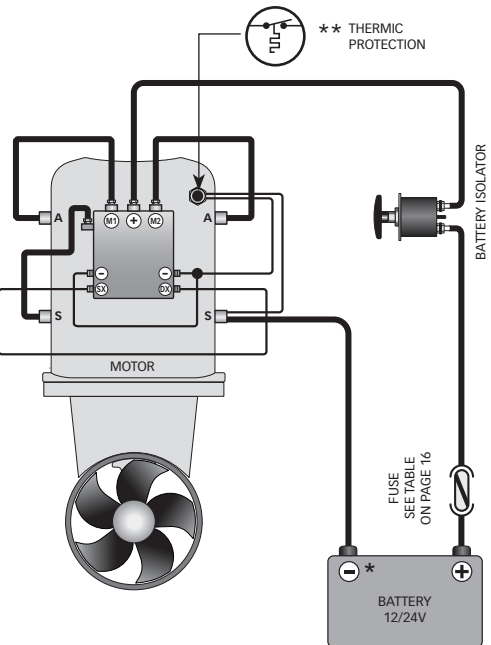
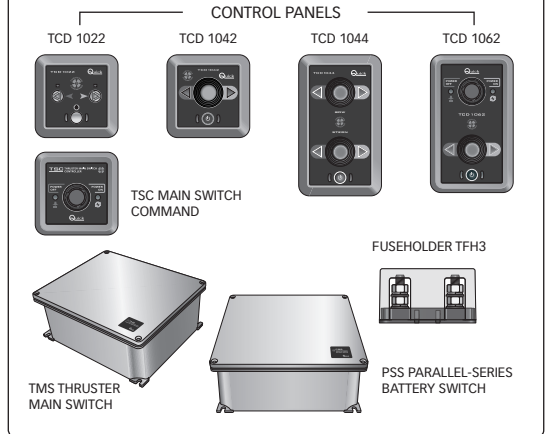

\* COMMON NEGATIVE FOR THE BATTERY GROUPS.

\*\* **WARNING:** IN CASE OF OVERTEMPERATURE, THE THERMAL PROTECTION ON THE MOTOR WILL OPEN AND INTERRUPT THE NEGATIVE CONTACT ON THE SOLENOID UNIT. WAIT AS LONG AS THE SYSTEM NEEDS TO REACTIVATE.



## WARNING



**WARNING:** this bow thruster is not designed for continuous use.

It is equipped with protections which limit its operation at a maximum time span, as reported on the controls' manual. It is strongly forbidden to bypass or modify such protections in order to increase the operating time span, lest voiding the warranty and thus lifting any responsibility from Quick SPA.



**WARNING:** make sure no swimmers or floating objects are in the vicinity before switching on the thruster.



**WARNING:** there must not be flammable materials in the peak or in the area where the Bow Thruster motor is.



**WARNING:** do not operate the bow thruster out of the water for more than 10 seconds.



**WARNING:** during mooring, it is recommended not to leave in the water any free line, which may be sucked in by the propellers, thus leading them to break.

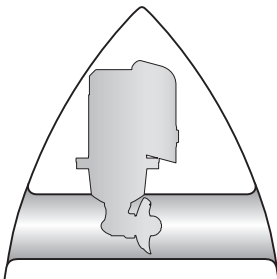
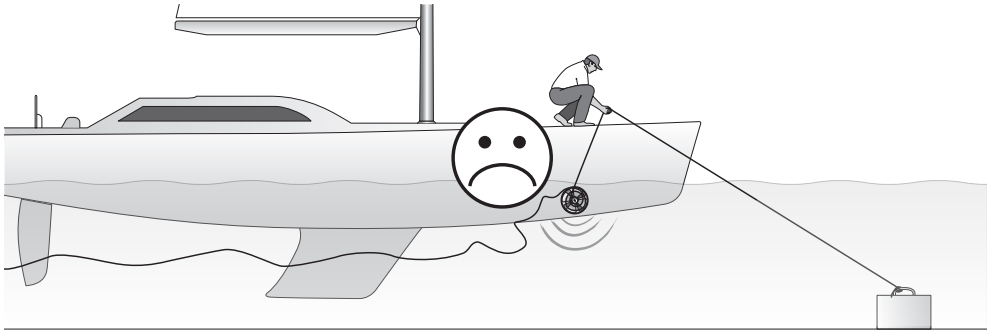

**NOTE:** the bow thruster must be installed with the propeller on the right-hand side of the gearleg (see figure)

In case the bow thruster needs to be installed on the opposite position, the connection of the two wires (blue and grey) to the control cable on the reversing contactor unit must be inverted.

## USE OF BOW THRUSTER

### START-UP

Start-up happens following activation of a TCD panel.

To use the thruster refer to the manual of the TCD control.





Quick® Thrusters are made in materials that are resistant to the sea environment: In any case, it is indispensable to periodically remove salt deposits that form on the outer surfaces to avoid corrosions and consequent system inefficiency.

**WARNING:** make sure that the power supply to the electric motor is not switched on when maintenance operations are carried out.

Dismantle once a year, following the points below:

- Clean propeller (30), tunnel and gearleg (19).
- Replace the anode (32) (carry out this operation more often if needed).
- Replace the propeller if damaged or worn out.
- Check the tightness of all screws.
- Ensure that there is no water seepage inside.
- Check that all electrical connections are well tightened and oxide-less.
- Check that the batteries are in good conditions.

**WARNING:** do not paint the anode (32), the sealing and the gearleg' shaft where the propeller is lodged.

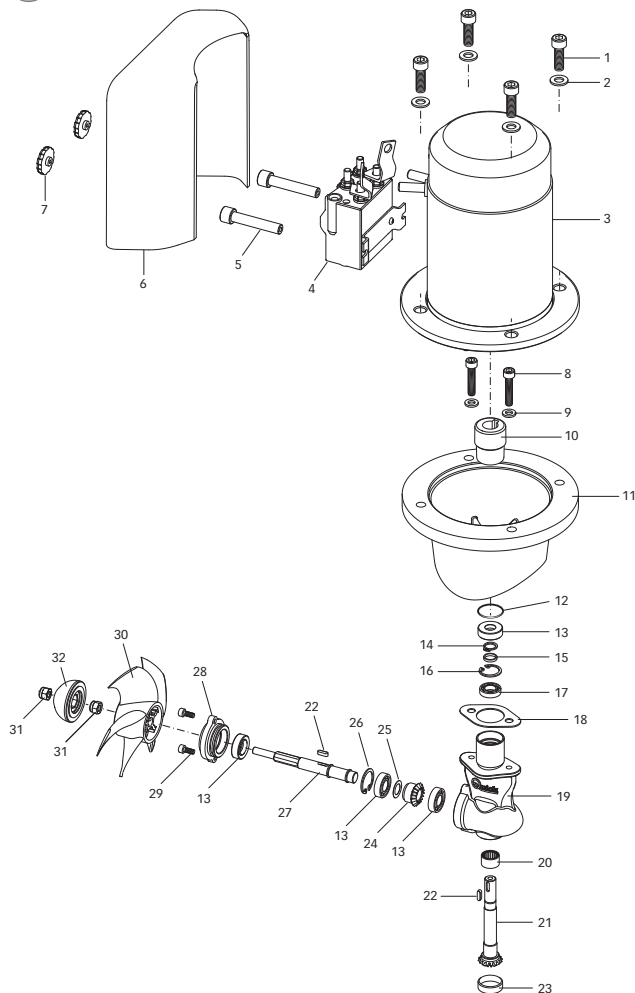

## BTQ 1102512

POS.	DESCRIPTION
1	MOTOR MOUNTING SCREW
2	MOTOR MOUNTING WASHER
3	MOTOR 1,3KW 12V
4	REVERSING CONTACTOR UNIT T6411-12
5	CARTER "A" SPACER
6	CARTER REVERSING CONTACTOR UNIT
7	FASTENERS CARTER REVERSING CONTACTOR UNIT
8	GEARLEG MOUNTING SCREW
9	WASHER
10	PROPELLER COUPLING
11	MOTOR FLANGE
12	O-RING
13	OIL SEAL
14	EXTERNAL SEEGER
15	SHAFT SPACER
16	INTERNAL SEEGER
17	BEARING
18	GEARLEG GASKET
19	GEARLEG
20	BEARING
21	SHAFT BEVEL GEAR PAIR
22	KEY
23	OIL SEAL
24	CROWN BEVEL GEAR PAIR
25	WASHER
26	INTERNAL SEEGER
27	GEARLEG OUTPUT SHAFT
28	GEARLEG FLANGE
29	SCREW
30	PROPELLER
31	SELF-BRAKING NUT
32	ANODE



**WARNING:** make sure that the power supply to the electric motor is not switched on when maintenance operations are carried out.

Dismantle once a year, following the points below:

- Clean propeller (31), tunnel and gearleg (20).
- Replace the anode (33) (carry out this operation more often if needed).
- Replace the propeller if damaged or worn out.
- Check the tightness of all screws.
- Ensure that there is no water seepage inside.
- Check that all electrical connections are well tightened and oxide-less.
- Check that the batteries are in good conditions.



**WARNING:** do not paint the anode (33), the sealing and the gearleg' shaft where the propeller is lodged.

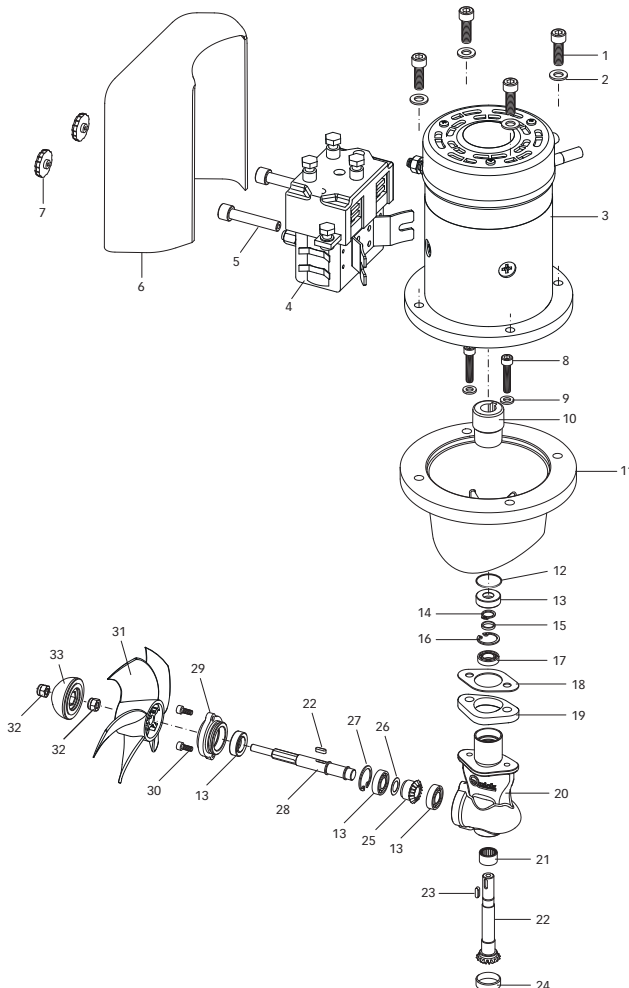

## BTQ 1253012

## BTQ 1254012

POS.	DESCRIPTION
1	MOTOR MOUNTING SCREW
2	MOTOR MOUNTING WASHER
3A	MOTOR 1,5KW 12V
3B	MOTOR 2,2 KW 12V
4	REVERSING CONTACTOR UNIT 150A 12V
5	CARTER "A" SPACER
6	CARTER REVERSING CONTACTOR UNIT
7	FASTENERS CARTER REVERSING CONTACTOR UNIT
8	GEARLEG MOUNTING SCREW
9	WASHER
10	PROPELLER COUPLING
11	MOTOR FLANGE
12	O-RING
13	OIL SEAL
14	EXTERNAL SEEGER
15	SHAFT SPACER
16	INTERNAL SEEGER
17	BEARING
18	GEARLEG GASKET
19	SPACER
20	GEARLEG
21	BEARING
22	SHAFT BEVEL GEAR PAIR
23	KEY
24	OIL SEAL
25	CROWN BEVEL GEAR PAIR
26	WASHER
27	INTERNAL SEEGER
28	GEARLEG OUTPUT SHAFT
29	GEARLEG FLANGE
30	SCREW
31	PROPELLER
32	SELF-BRAKING NUT
33	ANODE

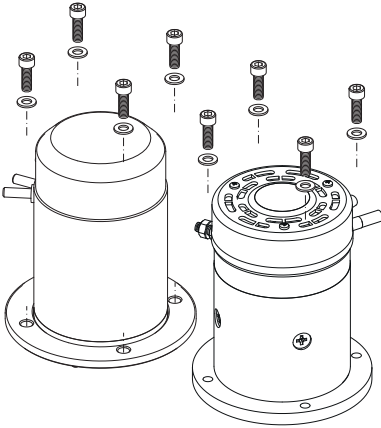

OSP MOT 1300W 12V BTQ110-140+T  
OSP MOT 1500W 12V BTQ125-140+T  
OSP MOT 2200W 12V BTQ125-140+T

FVEMFEL13121400  
FVEMFEL15121400  
FVEMFEL22121400

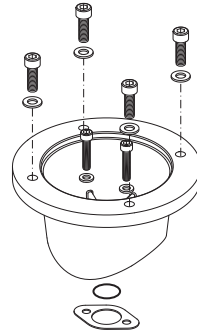

OSP PROPELLER FLANGE KIT BTQ110-125

FVSGFLBTQ110A00

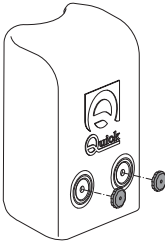

OSP KIT CARTER 'A' BTQ

FVSGCARTABTQA00



OSP GEARLEG BTQ110 KIT  
OSP GEARLEG BTQ125 KIT

FVSGGBBT1100A00  
FVSGGBBT1250A00

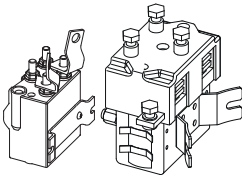

OSP REVERSING CONTACTOR UNIT KIT T6411-12 BTQ FVST64111200A00  
OSP REVERSING CONTACTOR UNIT KIT 150A 12V FVSGRCT15012A00

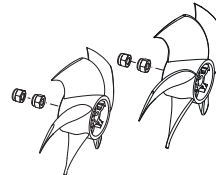

OSP PROPELLER D110 KIT  
OSP PROPELLER D125 KIT

FVSGEL110000A00  
FVSGEL125000A00



OSP COUPLING BTQ 110-125 KIT

FVSGG1101250A00



OSP PROPELLER ANODE BTQ110-125 KIT

FVSGANBTQ110A00

**BOW THRUSTERS**  
**DIMENSIONI / DIMENSIONS mm (inch)**



**BTQ110 25 12**

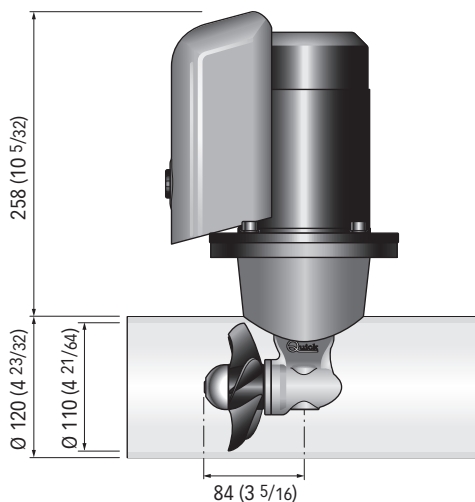

**BTQ125 30 12**

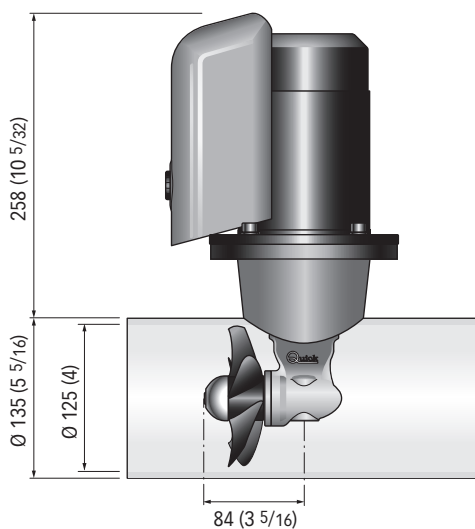

**BOW THRUSTERS**  
**DIMENSIONI / DIMENSIONS mm (inch)**



**BTQ125 40 12**

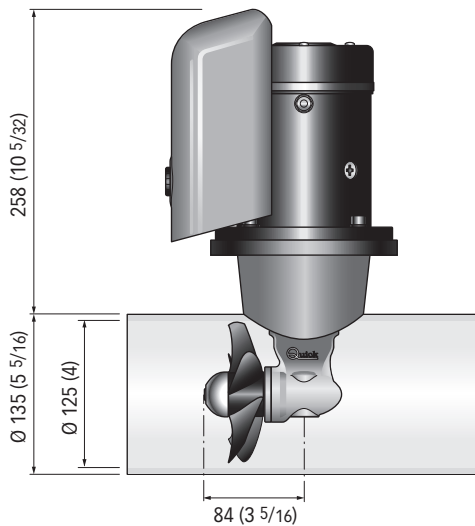

**BOW THRUSTERS**  
**SISTEMA BASE / BASIC SYSTEM**



**BASIC SYSTEM**  
**BTQ110**

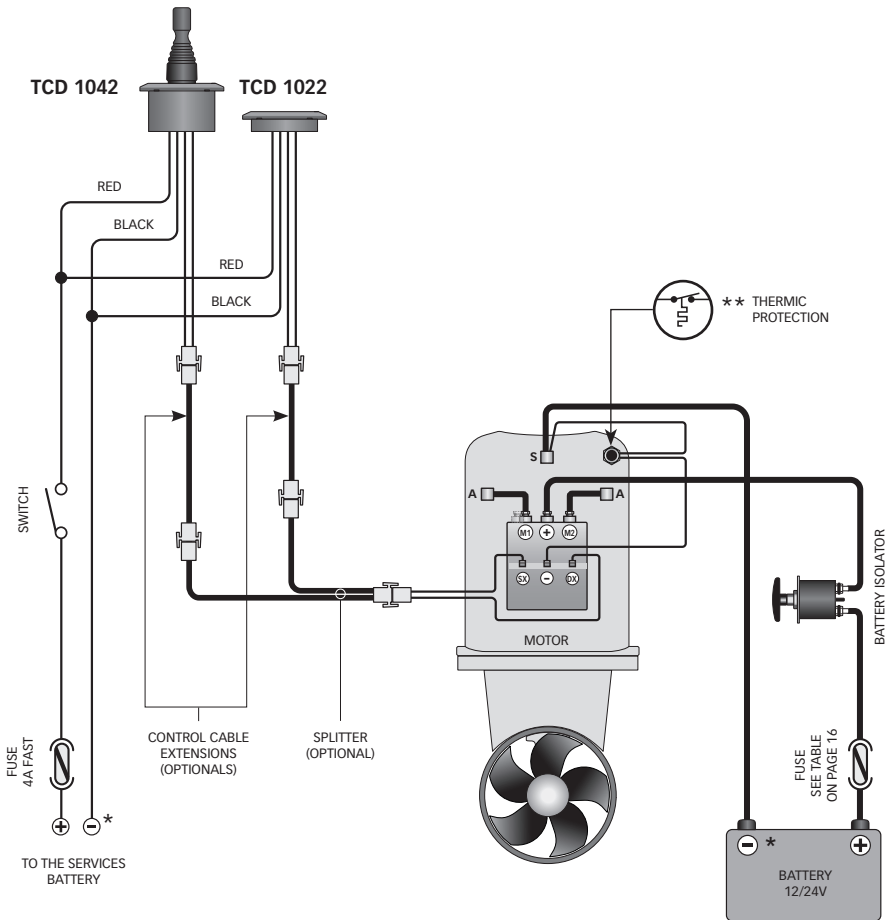

\* NEGATIVO DEI GRUPPI BATTERIA IN COMUNE.  
 \* COMMON NEGATIVE FOR THE BATTERY GROUPS.

\*\* **ATTENZIONE:** IN CASO DI SOVRATEMPERATURA LA PROTEZIONE TERMICA SUL MOTORE SI APRIRÀ E INTERROMPERÀ IL CONTATTO NEGATIVO SUL TELERUTTORE. ATTENDERE IL TEMPO NECESSARIO ALLA RIATTIVAZIONE.

\*\* **WARNING:** IN CASE OF OVERTEMPERATURE, THE THERMAL PROTECTION ON THE MOTOR WILL OPEN AND INTERRUPT THE NEGATIVE CONTACT ON THE SOLENOID UNIT. WAIT AS LONG AS THE SYSTEM NEEDS TO REACTIVATE.

**BOW THRUSTERS**  
**SISTEMA BASE / BASIC SYSTEM**



**BASIC SYSTEM**  
**BTQ125**

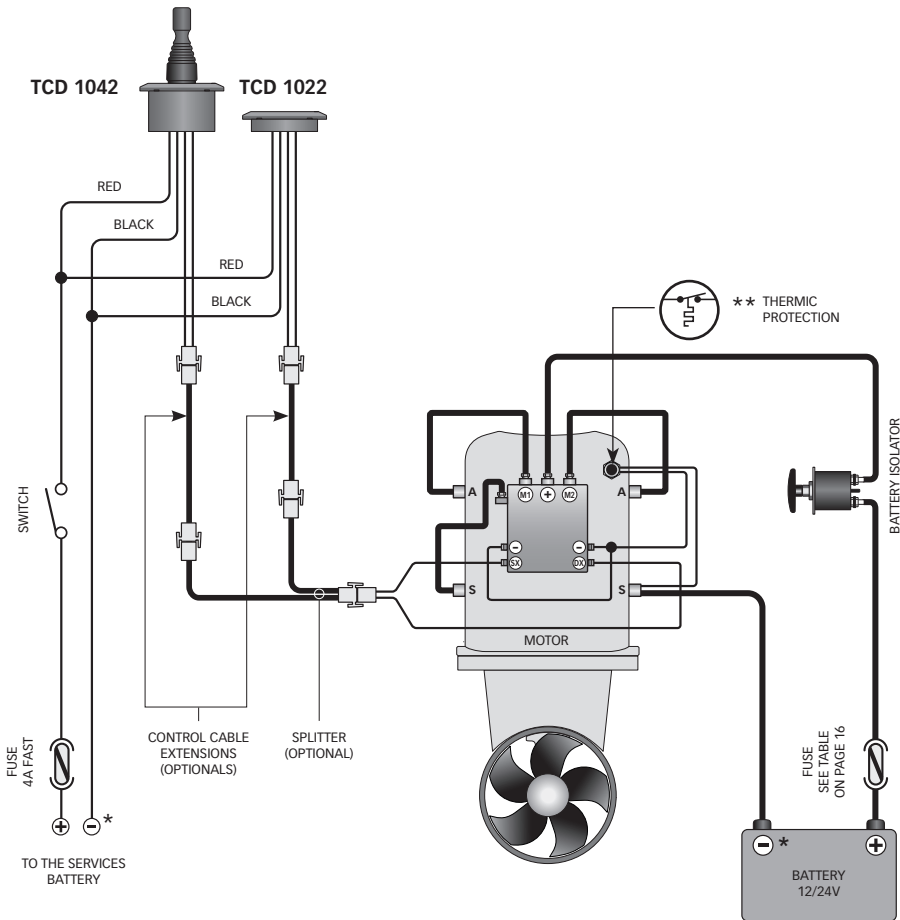

\* NEGATIVO DEI GRUPPI BATTERIA IN COMUNE.  
 \* COMMON NEGATIVE FOR THE BATTERY GROUPS.

\*\* **ATTENZIONE:** IN CASO DI SOVRATEMPERATURA LA PROTEZIONE TERMICA SUL MOTORE SI APRIRÀ E INTERROMPERÀ IL CONTATTO NEGATIVO SUL Teleruttore. ATTENDERE IL TEMPO NECESSARIO ALLA RIATTIVAZIONE.

\*\* **WARNING:** IN CASE OF OVERTEMPERATURE, THE THERMAL PROTECTION ON THE MOTOR WILL OPEN AND INTERRUPT THE NEGATIVE CONTACT ON THE SOLENOID UNIT. WAIT AS LONG AS THE SYSTEM NEEDS TO REACTIVATE.

# BOW THRUSTERS

## 110 / 125

R002A

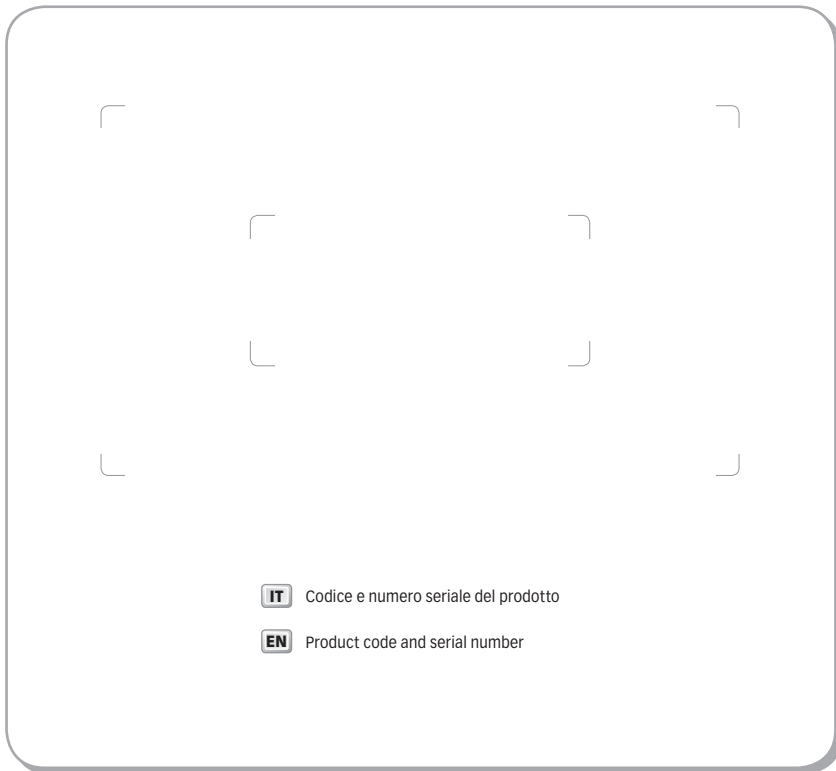

**Quick**<sup>®</sup>  
Nautical Equipment

QUICK<sup>®</sup> S.p.A. - Via Piangipane, 120/A - 48124 Piangipane (RAVENNA) - ITALY  
Tel. +39.0544.415061 - Fax +39.0544.415047  
[www.quickitaly.com](http://www.quickitaly.com) - E-mail: [quick@quickitaly.com](mailto:quick@quickitaly.com)