



a xylem brand

USA

Jabsco, 100 Cummings Center, Ste. 535-N,
Beverly, MA 01915
Tel: +1 978 281 0440 Fax: +1 978 283 2619

UK

Jabsco, Bingley Road, Hoddesdon, Hertfordshire, EN11 0BU
Tel: +44 (0) 1992 450 145 Fax: +44 (0) 1992 467 132

JAPAN

NHK Jabsco Co Ltd, 3-21-10, Shin - Yokohama Kohoku-ku,
Yokohama 222
Tel: +81 (0) 45 475 8906 Fax: +81 (0) 45 475 8908

GERMANY

Jabsco GmbH, Oststraße 28, 22844 Norderstedt
Tel: +49 (0) 40 53 53 73 0 Fax: +49 (0) 49 53 53 73 11

ITALY

Jabsco Italia, s.r.l., Via Tommaseo, 6, 20059 Vimercate, Milano
Tel: +39 039 685 2323 Fax: +39 039 666 307

Discover Jabsco at www.jabsco.com

Warranty: All products of the company are sold and all services of the company are offered subject to the company's warranty and terms and conditions of sale, copies of which will be furnished upon request

© 2013 Xylem Inc. All right reserved.

Jabsco is a trademark of Xylem Inc. or one of its subsidiaries.

43001-0559 Rev. B 10/2013



a xylem brand

HYDRO AIR

Air Operated
Automatic
Bilge Switch

- FR** Interrupteur de cale automatique à commande pneumatique
- DE** Automatischer Hydro-Air Bilgepumpenschalter
- IT** Interruttore automatico pneumatico per sentina
- NL** Luchtdrukbediende automatische lenspompschakelaar
- SE** Luftbrycksdriven länsautomatik
- ES** Conmutador de sentina automatico operado por aire
- PT** Interruptor de porão automático operado a ar
- DK** Luftaktiveret Lænsekontakt
- FI** Ilmakäyttöinen automaattinen pillssikytin
- GR** Αυτόματος διακόπτης σεντίνας, λειτουργεί με την πίεση του αέρα
- TR** Hava ile çalışan otomatik sintine şalteri
- JP** 空気式自動ビルジ・スイッチ

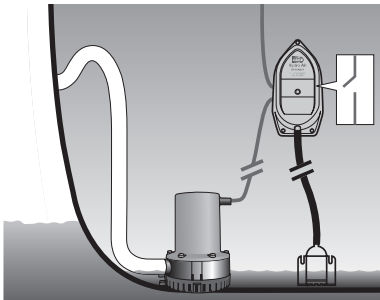
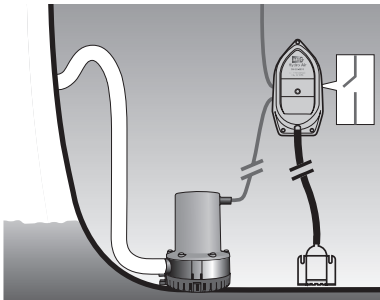

Hose Kit
Part No.
59406-1000



Air Bell Kit
Part No.
59407-1000



Part Nos:

59400-0012 12 Volt DC 0-20 Amps

59400-0024 24 Volt DC 0-10 Amps

