



Washdown — 32605/32900-Series

4.0 GPM (15 LPM) Marine Pumps

FEATURES

- Self-Priming to 10 ft. (3 m)
- Run Dry Without Damage
- Smooth Flow
- Powerful Motor with Thermal Overload Protection
- Snap-in Ports
- Sealed motor
- Thermal overload protection
- Meets USCG Regulation 183.410 and EN ISO 8846 MARINE (Ignition Protection Standards)
- Meets EN 50081-1 Electro Magnetic Compatibility



APPLICATION

32605/32900 – For commercial duty washdown/baitwell applications. Corrosion resistant sealed motor for harsh environment use. Baitwell is a full flow application.

WARNING!



Explosion hazard. Do not pump gasoline, solvents, thinners or other flammable liquids. To do so can cause an explosion resulting in injury or death.



Models 32605/32900-Series

SPECIFICATIONS

- Pump Body – Glass Filled Polypropylene
- Pump Design – Multi-Chamber Diaphragm
- Suction Lift – Self-Priming to 10 ft. (3 m)
- Ports – 3/4" (19 mm) Hose Barb & GMT
- Motor – Permanent Magnet
- Shipping Weight – 5 lb (2.1 kg)

VARIATIONS MODELS	APPLICATION	GPM/LPM	VOLTS	SHUT-OFF psi (bar)	AMP DRAW		FUSE BREAKER*	COILED HOSE
					@ 10 psi	@ 40 psi		
32605-0092	WASHDOWN	4.0/15.1	12 Vdc	60 (4.3)	5	9	15	No
32605-0094	WASHDOWN	4.0/15.1	24 Vdc	60 (4.3)	3	6	10	No
32900-0092	WASHDOWN	4.0/15.1	12 Vdc	60 (4.3)	5	9	15	Yes
32900-0094	WASHDOWN	4.0/15.1	24 Vdc	60 (4.3)	4	6	10	Yes

* Customer supplied, not included with pump.

DIMENSIONAL DRAWINGS — INCHES (MILLIMETRES)

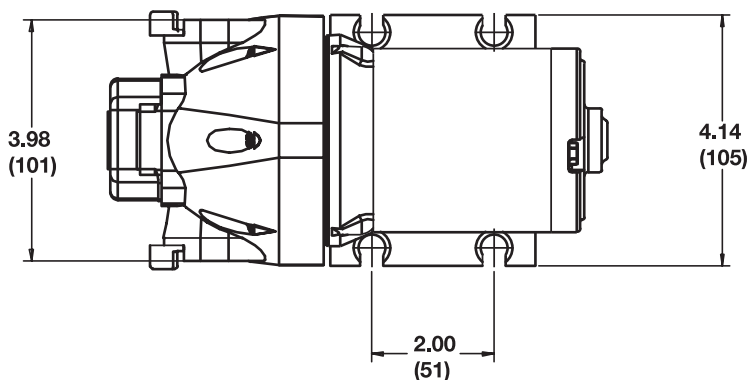
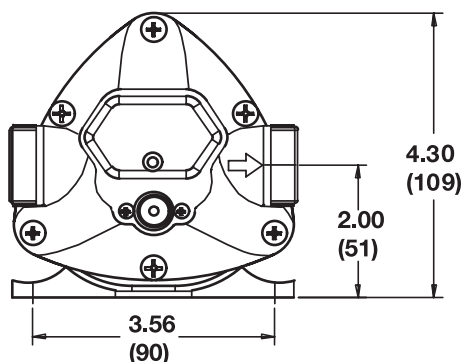

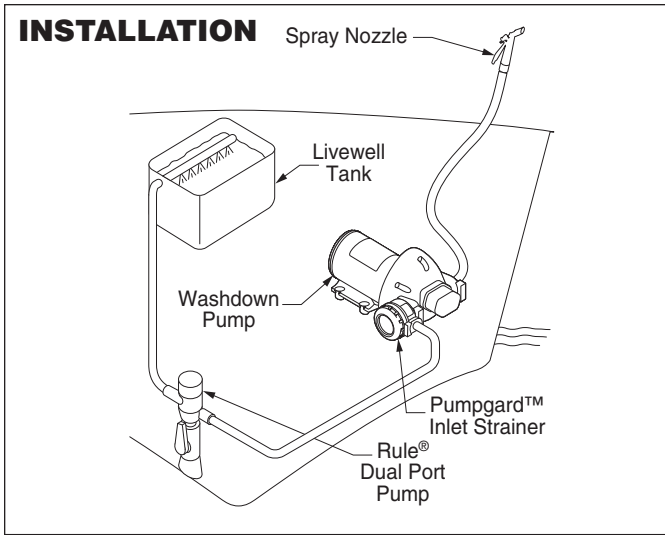
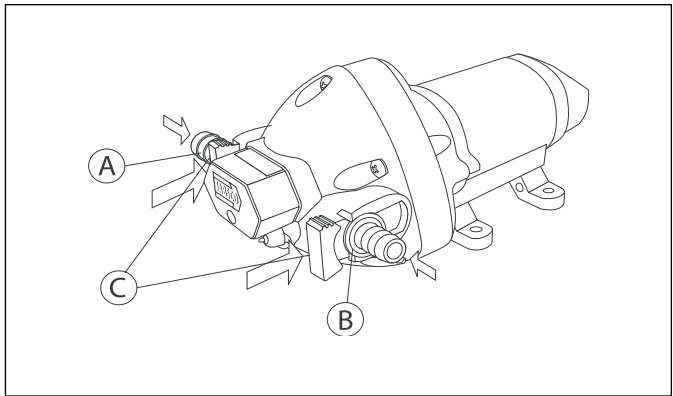

Fig. 1



Quick Easy Installation
Versatile Snap-in Ports

MOUNTING

Jabsco 4.0 GPM washdown pumps are self-priming and may be located above or below the water supply in a dry location. To vertically mount these units, it is best to do so with the motor on top. This will prevent water dripping on motor in the event of a leak. Place pump on a solid surface and secure with the four mounting screws being careful not to compress the rubber grommets which act as shock absorbers.

PLUMBING

IT IS RECOMMENDED THAT MARINE GRADE REINFORCED HOSE BE USED FOR ALL PLUMBING WITH THESE MODELS OF JABSCO PUMPS.

32605-Series – Washdown

Install the Pumpgard™ strainer (provided) to the hose from the water source (thru-hull seacock or water tank). Connect the Pumpgard™ strainer to the pump inlet port. Connect the pump discharge to a hose with a spray nozzle.

32605-Series – w/Rule® Dual Port (Fig. 1)

Install Rule® dual port pump to seacock. Connect hose from dual port pump to livewell/baitwell tank. Connect washdown hose from dual port pump to Pumpgard™ strainer, connect to pump inlet port. Connect hose from pump outlet to pressure nozzle.

WIRING

In an easily accessible location, install a switch to control electricity to the pump. The switch should have an amp rating equal to or greater than the fuse size specified for the pump. Turn the pump off when not used for extended periods or when the tank is empty.

The electrical circuit should be protected with an over-current protection device in the positive lead. See chart for proper size. The pump circuit should not include any other electrical loads. The open terminal on the pressure switch is positive. Black wire from the motor is negative.

Select wire size from chart below. Use total length of wire from the battery to pump and return. Chart allows for 3% voltage drop. If in doubt, use next larger wire size.

If you are not familiar with applicable electrical standards, have the unit installed by a qualified electrician.

After installation, check the voltage at the pump motor. Voltage should be checked when pump is operating. Full voltage must be available at the pump motor at all times.

Total length in feet	0-20 (0-6 m)	20-35 (6-11 m)	35-55 (11-17 m)
12 Volt	#14 AWG (2.5 mm ²)	#12 AWG (4 mm ²)	#10 AWG (6 mm ²)
24 Volt	#16 AWG (1.5 mm ²)	#14 AWG (2.5 mm ²)	#12 AWG (4 mm ²)

OPERATION

1. Open seacock (washdown or livewell applications).
2. Open hose bib and/or spray nozzle.
3. Turn on pump.
4. 32605-Series. Close spray nozzle/hose bib when water runs free of air. Pump is now ready for automatic demand operation.
5. For prolonged operation, pump must operate at full open flow.

CAUTION!



**Motor case will get hot.
Prolonged contact during operation may cause a burn.**



WARNING: DISCONNECT POWER TO PUMP AND OPEN VALVE TO RELIEVE WATER PRESSURE PRIOR TO SERVICING PUMP

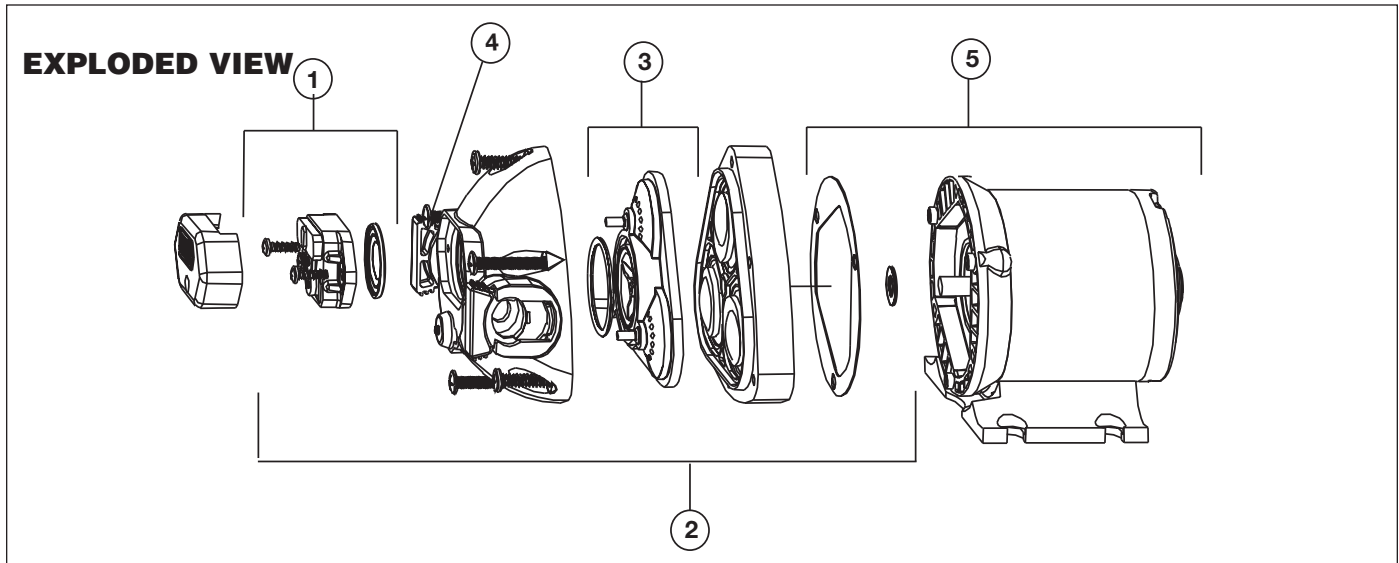

KEY	DESCRIPTION	QTY	31605-SERIES — PART NO.
1	Pressure switch	1	18916-1060
2	Pump head	1	18914-1060
3	Valve Kit	1	18911-1030
4	Slide clips	2	30647-1000
5	Motor	1	18919-0187
		1	18919-1080
7	* Pumpgard™ Strainer	1	46400-9500
	* Spray Nozzle US	1	30703-1000
	* Spray Nozzle EC Adapter	1	30704-1000
8	* Hose Coil, 25'	1	31910-3015

* Not shown in the above drawing

DISASSEMBLE

Pump Housing

(For numbers, refer to exploded view)

1. Disconnect power to the pump motor.
2. Remove the pressure switch cover and remove the two wire leads from the switch spade connectors.
3. Remove the six screws from the upper housing.
4. Remove the upper housing from the check valve and diaphragm/lower housing assemblies.

Check Valve Assembly

(To replace check valve only follow steps 1 through 6)

5. The check valve chamber and o-ring are located on the diaphragm/lower housing assembly.
6. Remove the check valve chamber subassembly from the diaphragm/lower housing subassembly (pull the valve chamber from the diaphragm).

Motor Replacement

7. To replace the motor only, follow steps 1 and 2, then disconnect 3 screws, and pull the pump head out. Replace the motor with washer and gasket.

REASSEMBLE

Pressure Switch Assembly

1. Install the switch diaphragm into upper housing.
2. Install the switch body over the diaphragm, align the screw holes and install the two mounting screws.

3. Reinstall the two wires onto the spade connectors, then install the switch cover and screw.

Check Valve Assembly

4. Install the o-ring into the o-ring groove located on the discharge side of the check valve chamber assembly.
5. Install the check valve chamber assembly into the diaphragm, thus aligning the check valve chamber with the diaphragm seal walls (push in to secure to the diaphragm).

Upper Housing Assembly

6. With the check valve chamber sub assembly installed on the diaphragm, place the upper housing assembly onto the pre-assembled lower housing sub assembly.
7. Align the cam with the motor "D" shaft and motor list, then slide the cam onto the motor shaft (lube the motor shaft with a small amount of light grease).
8. Check the discharge location (see arrow on front of port) for correct port orientation (discharge right is the standard position).
9. Install the six pump head screws through the upper housing, 3 screws will engage to lower housing. The other 3 screws will go through the lower housing into the front end bell assembly aligning the three pins on the front end bell with the 3 holes on the lower housing and tighten securely.

Motor Assembly

10. Install the pump head by following steps 6 through 9.

TROUBLESHOOTING

Symptom	Possible Cause(s)	Corrective Action
Pump will not prime or retain prime after operating	1. Air leak in suction line 2. Defective valve (Key 3) 3. Upper housing leaking 4. Suction lift too high 5. Debris in valve(s) (Key 3)	1. Repair or replace 2. Replace 3. Tighten bolts 4. Lower pump 5. Clean valve(s)
Pump runs but no fluid	1. Faulty suction piping 2. Defective valve (Key 3) 3. Suction lift too high 4. Clogged inlet 5. Inlet line valve closed	1. Repair or replace 2. Replace 3. Lower pump 4. Clean or replace 5. Open valve
Motor runs too hot	1. Voltage incorrect 2. Insufficient ventilation for motor	1. Check voltage 2. Insure proper ventilation
Flow rate is low	1. Piping or hose is damaged 2. Clogged valve (Key 3) 3. Worn valve (Key 3) 4. Voltage incorrect 5. Tank over pressurized	1. Clean or replace 2. Clear obstruction 3. Replace 4. Check voltage 5. Check tank pressure
Pump leaks	1. Upper housing loose 2. Pump head loose on motor 3. Switch loose (Key 1) 4. Defective Diaphragm	1. Tighten screws 2. Tighten pump head 3. Tighten switch 4. Replace pump head
Pump will not run	1. No electricity 2. Defective pressure switch (Key 1) 3. Motor has open circuit 4. Thermal protector has cut off	1. Check connections, fuse, breakers 2. Replace switch 3. Replace 4. Allow motor to cool 14-30 min.

CONVERSION TABLE

TO CONVERT	TO	MULTIPLY BY
Gallons, U.S.	Litres	3.785
Liters	Gallons, U.S.	0.264
Pounds/Sq. Inch	Bar	0.069
Bar	Pounds/Sq. Inch	14.5
Fahrenheit	Celsius	(°F-32) .556
Celsius	Fahrenheit	(°C X 1.8) + 32

**ACCESSORIES
SNAP-IN PORT SYSTEM**

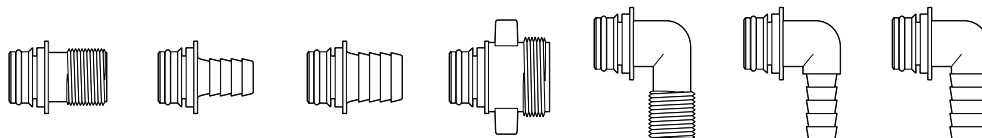

NOTE:
Use 306XX-1000 Series EPDM for potable water.

30649-1000	30654-1000	30653-1000	30650-1000	30655-1000	30651-1000	30642-1000
SNAP-IN PORT x 1/2" MALE QEST. STRAIGHT	SNAP-IN PORT x 1/2" HOSE BARB STRAIGHT	SNAP-IN PORT x 3/4" HOSE BARB STRAIGHT	SNAP-IN PORT x GARDEN HOSE STRAIGHT	SNAP-IN PORT x 1/2" MALE QEST. 90° ELBOW	SNAP-IN PORT x 1/2" HOSE BARB 90° ELBOW	SNAP-IN PORT x 3/4" HOSE BARB 90° ELBOW



Engineered for life

www.jabco.com

THE PRODUCTS DESCRIBED HEREIN ARE SUBJECT TO THE JABSCO THREE YEAR LIMITED WARRANTY, WHICH IS AVAILABLE FOR YOUR INSPECTION UPON REQUEST.

U.S.A. Jabco 666 E. Dyer Rd. Santa Ana, CA 92705 Phone: 714.557.4700 Fax: 714.628.8478	UNITED KINGDOM Jabco Bingley Road, Hoddesdon Hertfordshire EN11 0BU Tel: +44 (0) 1992 450145 Fax: +44 (0) 1992 467132	CANADA Fluid Products Canada 55 Royal Road Guelph, Ontario N1H 1T1 Tel: 519 821.1900 Fax: 519 821.2569	JAPAN NHK Jabco Company Ltd. 3-21-10, Shin-Yokohama Kohoku-Ku, Yokohama, 222 Tel: 045.475.8906 Fax: 045.475.8908	GERMANY Jabco GmbH Oststrasse 28 22840 Norderstedt Tel: +49-40-53 53 73 -0 Fax: +49-40-53 53 73 -11	ITALY Jabco Marine Italia Via Tommaseo, 6 20059 Vimercate, Milano Tel: +39 039 685 2323 Fax: +39 039 666 307
--	---	--	--	---	--