

SIDE-POWER
Thruster Systems

PJC221/222 SAC

S-linkControl Panel

EN Installation and user's manual v 2.1.3 SAC

Keep this
manual onboard!



PJC221



PJC222



SLEIPNER MOTOR AS

P.O. Box 519
N-1612 Fredrikstad
Norway
Tel: +47 69 30 00 60
Fax: +47 69 30 00 70

www.side-power.com
sidepower@sleipner.no



Made in Norway

© Sleipner Motor AS 2017

Contents

Product Features	3
Panel layout & functions	4
Display in normal use	5
Symbols explanations	6-7
HOLD calibration	8
Menu system	9
Menu system - Language - Stabilizer - default settings	10
Setup procedure.....	11
Menu system - Setup.....	12-17
System devices	12
2. PDC 201	13
3. PDC 101	13
6. RCRS-1 and RCRS-2.....	14
7. MSI8730	14
Hold calibration	15
Menu system - Info.....	16
Menu system - Panel Setup.....	17
Alarm system.....	18
Alarm descriptions	19
Technical specifications and measurements.....	20
Connections	21

DO NOT connect any other control equipment to the S-link controlled products except Side-Power original S-link products or via a Side-Power supplied interface product made for interfacing with other controls. Any attempt to directly control or at all connect into the S-link control system without the designated and approved interface, will render all warranties and responsibilities for the complete line of Side-Power products connected void and null. If you are interfacing by agreement with Sleipner and through a designated and approved interface, you are still required to also install an original Sidepower control panel to enable efficient troubleshooting if necessary

DECLARATION OF CONFORMITY



We, Sleipner Motor AS
P.O. Box 519
N-1612 Fredrikstad, Norway

declare that this product with accompanying standard remote control systems complies with the essential health and safety requirements according to the Directive 89/336/EEC of 23 May 1989 amended by 92/31/EEC and 93/68/EEC.

Control panel with S-link™ CAN-bus connection

Product features

- For proportional thruster control with AC Thrusters
- Finger tip control speed control with purpose designed joysticks
- Hold - function for easy docking, runs thrusters at selected power
- Back-lit LCD display with instant feedback
 - System status / alarms
 - Amount of thrust & direction of thrust
- Interactive multi-language menus
- CAN-Bus communication with thrusters and accessories
- Plug & play cables with compact connectors
- Diagnostics and system setup via panel
- Built-in audible alarm "buzzer"
- Connector for external "buzzer"/loud audible alarms
- Supports Side-Power retractable thrusters with or without Speed Control



Panel layout & functions

PJC-221

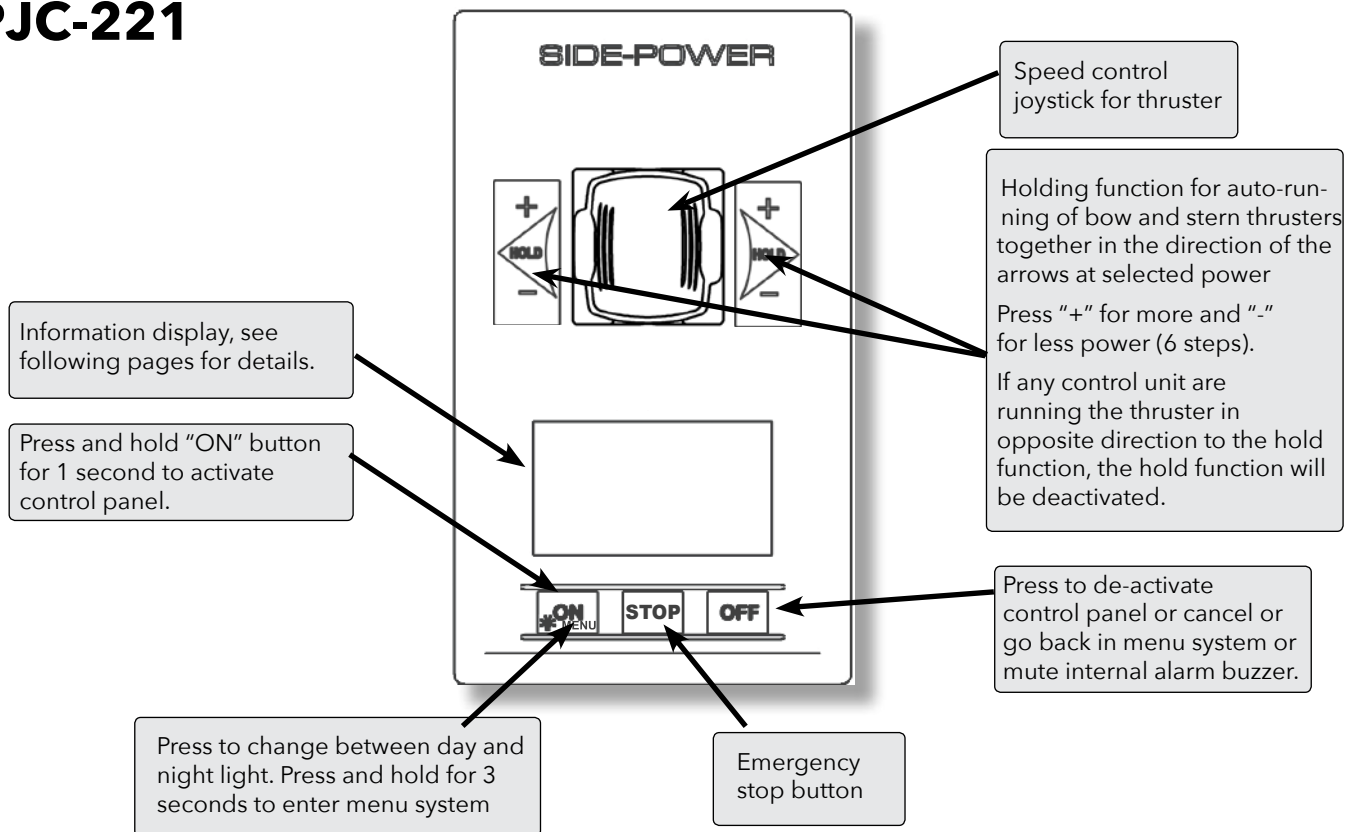

PJC-222

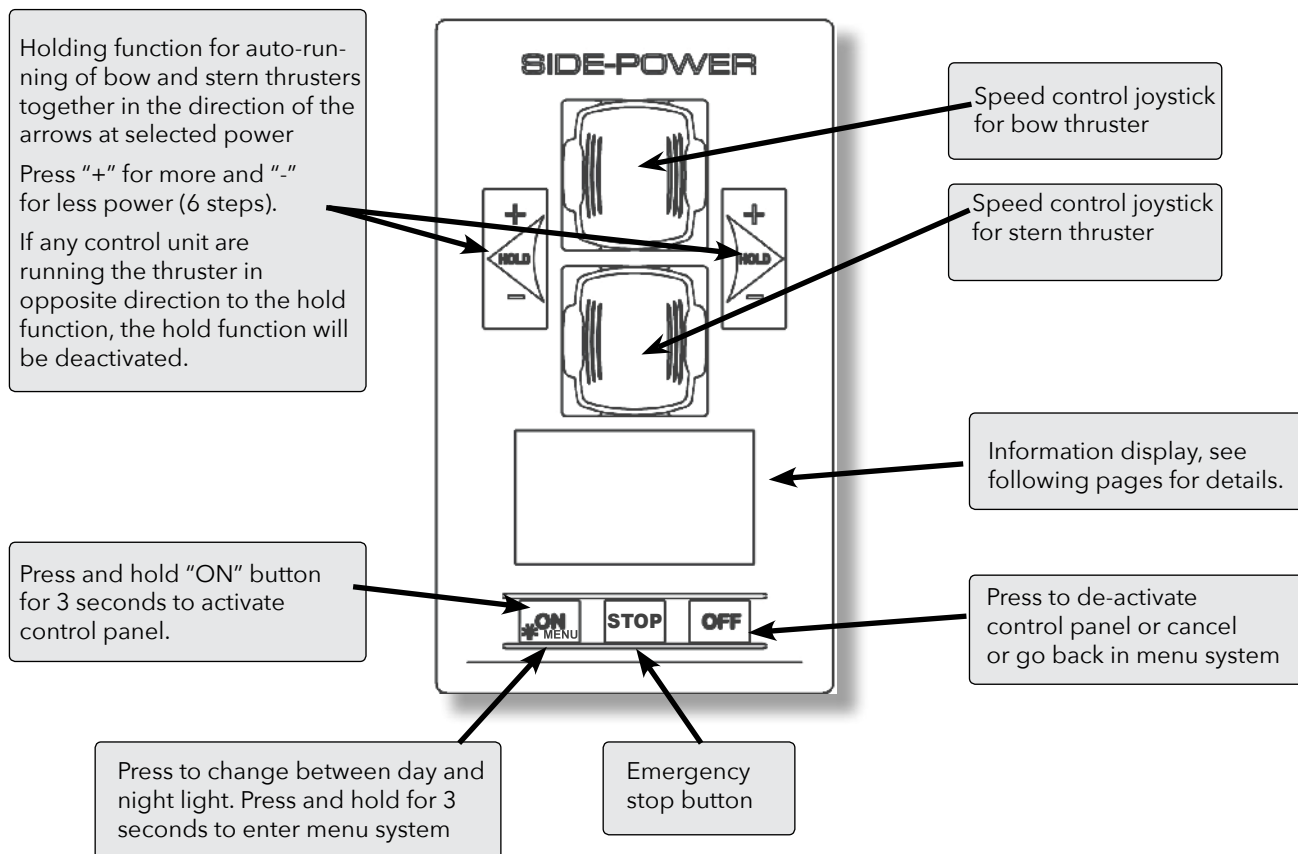

Display in normal use

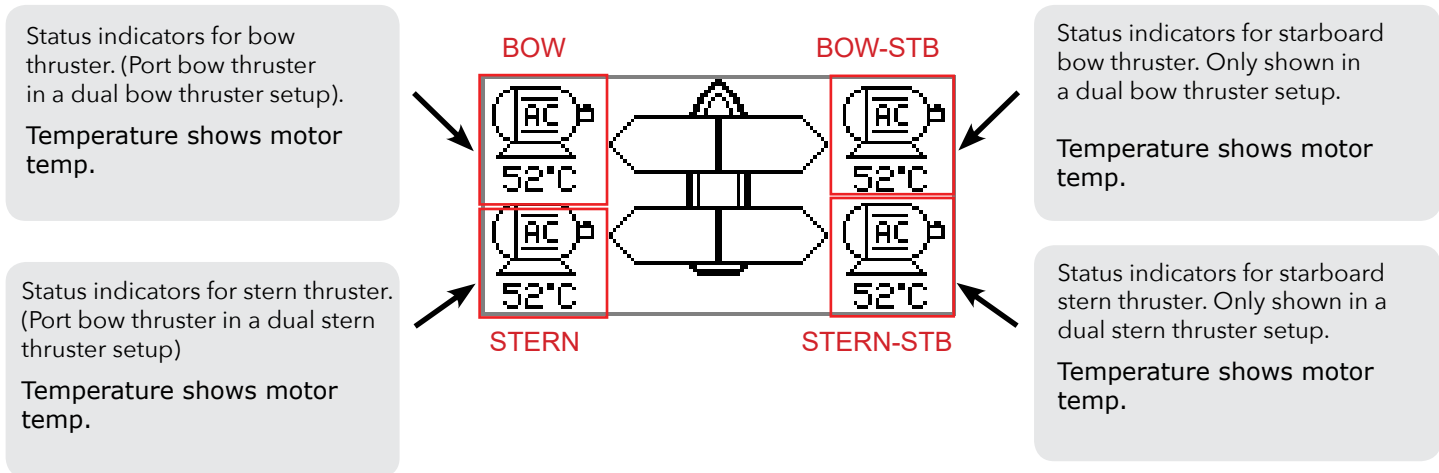

Examples of display view for different panels applications:

PJC221:
Dual AC Electric Bow thrusters

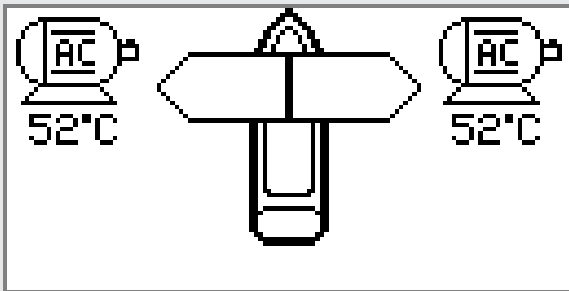

PJC222:
Dual AC Electric Bow thrusters
Dual AC Electric Bow thrusters

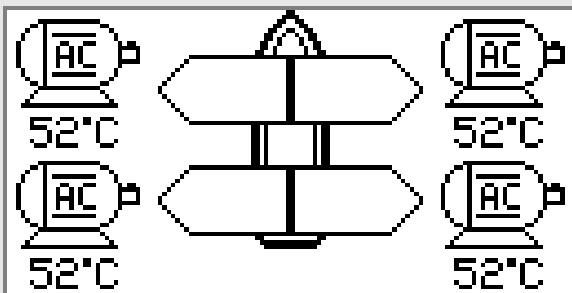

Symbols explanations

AC Thrusters:

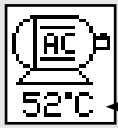

← Motor temperature indicator.

Retractable Thrusters:



Symbol shown when the thruster deploys.



Symbol shown when the thruster retracts.



Symbol shown when the thruster is in position OUT.

When the thruster is deployed and no input is given via the joysticks/buttons over a 10 second period, the panel will give an audible signal every 10th second to tell that the truster is still deployed.

Symbols explanations

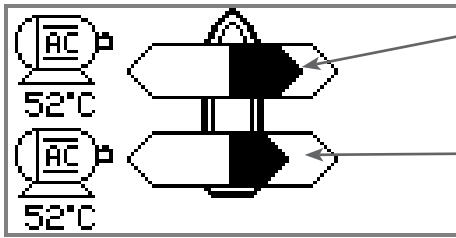

Thrust power and direction, Bow thruster(s)

Input from bow joystick on this panel.
The thrust indicator will be shown in this position on a single joystick panel if the thruster is defined as a bow thruster

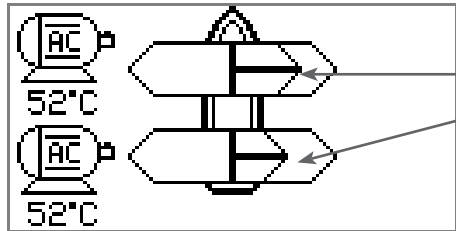

Thrust power and direction, Stern thruster(s)

Input from stern joystick on this panel
The thrust indicator will be shown in this position on a single joystick panel if the thruster is defined as a stern thruster.

Indicating amount of thrust set by other control units in the system, i.e additional PJC panels, 8700 Retract panel, input via 8730 S-link external switch interface, S-link remote control etc.

If two or more units are set to run the thruster in opposite direction, this information will not be shown.

FIRST TIME SETUP

After installation of an S-link thrusters system, a System Setup procedure to setup control panels, thrusters and additional equipment must be completed before the system can be used.

Write down all the S- Link devices and serial number in table on page 22.

HOLD function

The 'HOLD' function is for auto-running of bow and stern thrusters together in the direction of the arrows at selected power.

Press "+" for more and "-" for less power (6 steps). The 'HOLD' function is normally used to hold the boat into the dock while mooring. The 'HOLD' function can be deactivated by running any thruster in the opposite direction from any control unit.

Calibration

The 'HOLD' function can be calibrated to get balanced thrust from the bow and stern thruster.

See page 15 'HOLD CALIBRATION' for how to calibrate.

Warning signals when using 'HOLD' function

The internal and external (if fitted) buzzer will give the following warning signals:			
	Warning signals	Cause	Effect
1.	Single short beep every 2.4 sec.	<ul style="list-style-type: none">Voltage below 9.3V/17.5V (12V/24V system).Temperature above 85°C/185°F.	None
2.	Two short beeps every 2.4 sec.	<ul style="list-style-type: none">Voltage below 8.9V/16.3V (12V/24V system).Temperature above 100°C/212°F.	None
3.	Red backlight in display and continuous short beeps.	<ul style="list-style-type: none">Voltage below 8.5V/15V (12V/24V system).Temperature above 110°C/230°F.	None
4.	Red backlight in display and continuous short beeps.	If one or more of the thrusters enters an alarm state - Voltage below 8.0V/12.0V (12V/24V system) or temperature above 120°C/248°F.	"HOLD" function are cancelled and both thrusters will stop. Temperature must drop below 110°C/230°F before the thruster can be operated again. Low Voltage alarm must be reset from panel.

Menu system

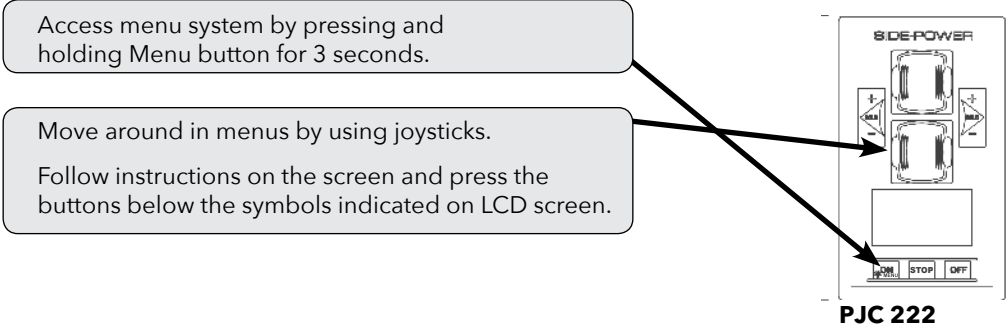

MAIN MENU ITEMS:
Move between main menu items with the (stern) joystick.

Language	Stabilizer (If installed)	Setup	Info	Default settings	Panel setup

BUTTON SYMBOLS
On the bottom line of the display, a symbol will be shown over the buttons below. These symbols will show what function each corresponding button has in the selected menu entry.

Return to previous menu.	Select highlighted menu text / Save edited parameter.	Edit highlighted parameter.	Cancel editing without saving.	This symbol indicates that the (stern) joystick is used to move between menu items / parameters.

Menu system



LANGUAGE

- Choose language by moving joystick: English, Norwegian, German, French, Spanish, Italian and Danish.
- Press the button below to set the language to the highlighted menu entry. A star (*) on each side indicates the language set.



(Default in systems with stabilizers)

STABILIZER

(Shown only for yachts equipped with a Side-Power Stabilizer system)

Press the button below to edit the selected parameter. ON/OFF will start to blink, use joystick to alter value.
Press the button below to save edited parameter to device.

1. Stabilizer:

- Values: ON/OFF
- Switches the stabilizer ON or OFF.



2. AnySpeed:

- Values: ON/OFF
- Switches the zero speed/at anchor stabilization ON or OFF.

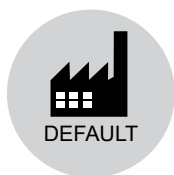

DEFAULT SETTINGS

- Reset all settings to factory default - follow instructions on screen
- Press the button below to confirm reset
- The following parameters/values will be set to the factory settings:

Language = English
Backlight Level = 5
Backlight Night Color = Green
Backlight Nightlevel = 1
Timer Auto-Off = 05 min
Hold Calibration = 70% Bow and Stern

All system devices will be erased from memory.
(Setup procedure must be followed to reconfigure the system)

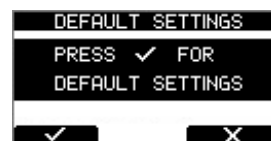

Setup procedure

The setup procedure requires knowledge of the serial number and location of all the S-link devices.

Write this down in the form on the last page to have the information at hand when doing a manual setup.

At the first startup of a new system, one of the two screens below will be shown:



1. SETUP DO NOT MATCH SYSTEM.

✓ FOR AUTO SETUP

New devices found. Not in conflict with other devices. Press button below the -symbol to auto setup.

Thrusters can not be operated to auto setup is completed.



2. RUN SETUP! DEVICES IN CONFLICT!

Detected devices in conflict. Two or more thrusters defined as same instance (bow/stern/bow STB/Stern STB). Run Setup procedure to correct.

Thrusters cannot be operated until seup is completed.



2.1

Press and hold the button marked "MENU" for 3 seconds to enter the menu system. Use the (stern) joystick to select "SETUP", Press button below the -symbol to enter the "SETUP"-menu.



2.2

Use the (stern) joystick to select "SYSTEM DEVICES", Press button below the -symbol to enter the "SYSTEM DEVICES"-menu.



2.3

Use the (stern) joystick to set the pin code one number at the time, press button below the -symbol to jump to next number and confirm. The pin code is "9 9 9 9".

NOTE: Re-entering the SYSTEM DEVICES menu within 15 minutes does not require entering PIN code



2.4

For about 2 seconds an hourglass will appear while scanning the S-link for devices. The devices found in the system is now displayed with their instance (thruster type and location) and serial number.

Go through all devices and make sure that they are set to the correct instance and function (refer to detailed instructions in the SETUP section of "Menu System"-chapter).



Press button below the -symbol to save setting and return to "Setup"- Menu.

Menu system - SETUP



(Default in systems without stabilizers)

SETUP

Move between menu items with the (stern) joystick.
Press the button below  to select the highlighted menu entry.
Press the button below  to return to the previous menu.

Setting done under SETUP will be sent to all other panels in the system.

SYSTEM DEVICES

View all devices connected to S-Link and manually change setup values.

A PIN code is required to enter the SYSTEM DEVICES menu.
Use the (stern) joystick to set the pin code one number at a time, press button below the -symbol to jump to next number and confirm.
The pin code is "9 9 9 9".

The number of devices found is shown in the upper right corner of the display.

Use (stern) joystick to move between the installed devices.

The list of devices found can fill more than one screen.
A scroll bar indicates the position of the selected item.

NOTE: Re-entering the SYSTEM DEVICES menu within 15 minutes does not require re-entering PIN code.







(Default in systems without stabilizers)

AC system - Setup

2. PDC 201

(SAC Controller)

Press the button below  to return to the previous menu.

Press the button below  to edit the selected parameter.

Parameter value will start to blink, use joystick to alter value.

Press the button below  to save edited parameter to device

Press the button below  to cancel editing without saving.

2.1 Location

Values: BOW/STERN/BOW-STB/STERN-STB

Set the location for selected device. Use BOW or STERN in a conventional thruster system. In a system with two bow or stern thrusters (i.e a catamaran), use BOW or STERN for port thruster, BOW-STB or STERN-STB for starboard thruster.



2.2. Direction

Values: Normal (default)/Inverted

Switches between Normal and Inverted running direction for the thruster.



3. PDC 101

(SAC Controller) (This device is not able to edit. Pre-setup from factory.)

Press the button below  to return to the previous menu.

PDC101 must be setup by authorized personnel.

Firmware version and serial number is Not Available (NA).

3.1 Location

Values: BOW/STERN/BOW-STB/STERN-STB

BOW or STERN in a conventional thruster system.

In a system with two bow or stern thrusters (i.e a catamaran), BOW and STERN is port thruster, BOW-STB and STERN-STB is starboard thruster.

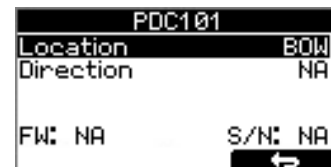

3.2. Direction

Values: NA (Not Available)





(Default in systems without stabilizers)

6. RCRS-1 and RCRS-2

(S-Link Radio Remote Receiver)

Move between parameters with the (stern) joystick.

Press the button below  to return to the previous menu.

Press the button below  to edit the selected parameter.

Parameter value will start to blink, use joystick to alter value.

Press the button below  to save edited parameter to device

Press the button below  to cancel editing without saving.

6.1 BOW/STERN Thrust

Values: 0-100% (Default 75%)

Set the amount of thrust given by the remote control.

In a bow/stern configuration, try to balance the thrust so that the boat moves straight sideways when both thrusters are operated simultaneously with input from the remote only.

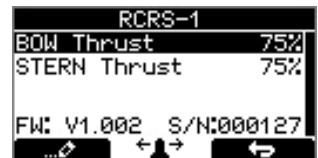

7. MSI8730

(S-Link Interface)

Move between parameters with the (stern) joystick.

Press the button below  to return to the previous menu.

Press the button below  to edit the selected parameter.

Parameter value will start to blink, use joystick to alter value.

Press the button below  to save edited parameter to device

Press the button below  to cancel editing without saving.

7.1 Location

Values: BOW/STERN/BOW-STB/STERN-STB

Set the location for selected device. Use BOW or STERN in a conventional thruster system. In a system with two bow or stern thrusters (i.e a catamaran), use BOW or STERN for port thruster, BOW-STB or STERN-STB for starboard thruster.



7.2 Thrust

Values: 0-100% (Default 70%)

Set the amount of thrust given by the remote control.

In a bow/stern configuration, try to balance the thrust so that the boat moves straight sideways when both thrusters are operated simultaneously with input from the remote only.





(Default in systems without stabilizers)

HOLD CALIBRATION

Calibrates the HOLD-function to get balanced thrust from the bow and stern thruster. If only one thruster or PJC221/PJC211 you will not get any balanced thrust, but you can adjust the maximum thrust from HOLD buttons. Hold-button represents 1/6 if the calibrated value.

Note! HOLD CALIBRATION is not available until SETUP is completed.

To start calibration, press the "+"-Hold button in the desired direction. For a first time calibration, the thrusters will start at 70%. A system previously calibrated will start with the last amount of thrust set.

Adjust power with the joystick.

Press the button below  to save the calibration values.

Press the button below  to cancel calibration without saving.

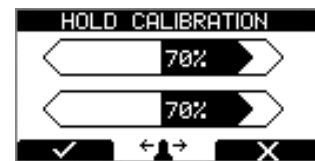

Note: Setup calibration in one direction sets values for both directions.



Menu system - INFO





INFO

- Move between menu items with the (stern) joystick.
- Press the button below  to select the highlighted menu entry.
- Press the button below  to return to the previous menu.



THRUSTER INFO

Display info about the thrusters in the system.
The number of thrusters/controllers found is shown in the upper right corner of the display.

Use (stern) joystick to move between the installed devices.
Press the button below  to select the highlighted menu entry.
Press the button below  to return to the previous menu.

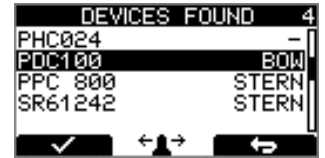

The list of devices found can fill more than one screen. A scroll bar indicates the position of the selected item.
The joystick(s) operates the thrusters as normal while info is displayed. This will be useful for troubleshooting, service and general system diagnostics.
List will only show devices present on the S-link.

PDC101 and PDC 201 (Controller for AC electric thrusters)

Motor Speed: RPM on motor output shaft
Motor Power: Motor power consumption in % (PDC201 only)
Motor Temp: Temperature measured in motor
Thrust: Thrust level from joystick/hold buttons
Press the button below  to return to the previous menu.

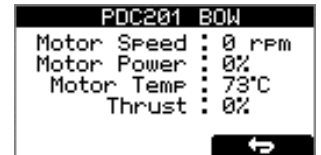

PANEL INFO

Display info about the control panel



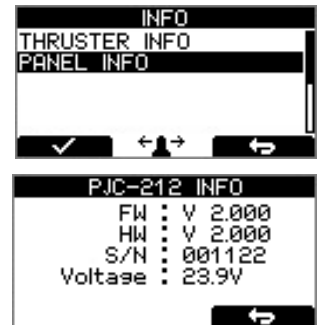

FW: Version number, Firmware
HW: Version number, Hardware
S/N: Serial number of the control panel
Voltage: S-link system voltage measured at the panel
Press the button below  to return to the previous menu.

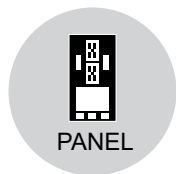

Menu system - PANEL SETUP



PANEL SETUP

- Move between parameters with the (stern) joystick.
- Press the button below  to return to the previous menu.
- Press the button below  to edit the selected parameter.
- Parameter value will start to blink, use joystick to alter value.
- Press the button below  to save the edited parameter.
- Press the button below  to cancel editing without saving.

BACKLIGHT LEVEL

Values: 1-5

Set level of panel backlight in daylight mode.

1 is lowest intensity, 5 is the highest.



BACKLIGHT NIGHT COLOR

Values: GREEN, BLUE, RED, WHITE

Select color of backlight in nightlight mode .



BACKLIGHT NIGHT LEVEL

Values: 1-3

Set level of panel backlight in daylight mode,

1 is lowest intensity, 3 is the highest.



TIMER AUTO-OFF

Values: OFF, 01-60 min

Set the time from last use to auto panel shutdown.

Set from 1-60 minutes in 5 minute steps (1 minute steps from 1 to 5 minutes) or OFF (panel will not turn off automatically).



UNIT TEMPERATURE

Values: CELSIUS (Default), FAHRENHEIT

Set the panel temperature displaying unit.



WHEN RETRACT IS OUT

Values: NO WARNING (Default), WARNING EVERY 10sec

Select 'WARNING EVERY 10sec' for external buzzer or lamp warning every 10 seconds when retract is out. This will activate the internal relay for 0.2 seconds every 10 seconds while the retract is out. See page 26 for buzzer connections.



RELAY OUTPUT

Values: ALERT LEVEL 1 , ALERT LEVEL 2 , ALERT LEVEL 3 (Default)

ALERT LEVEL 1: When using the HOLD Function the relay output warns if the motor temperature is getting high or if the voltage is getting low.

ALERT LEVEL 2: The relay output warns for all alarms and warnings in the S-link system only when any device is sending thrust. Even when the panel is turned OFF.

ALERT LEVEL 3: The relay output warns for all alarms and warnings in the S-link system. Even when the panel is turned OFF.



See 'Alarm descriptions' in "Ext. buzzer activation at Alert Level" column for specific alarm action.

Alarm System

When there is an alarm or a fault, the panel will show this alarm situation by changing LCD display backlight to red color.

The panel will also change to show "Alarm Info"  on the bottom of the screen, indicating that by pressing the corresponding button below, you will get information about what the problem is (examples below). Entering "Alarm Info" menu will silence the alarm on all PJC221 and PJC222 panels.

Some alarms needs an reset to stop alerting.

Example PJC 222:

(Button below this symbol pressed)

Alarm code

Alarm description

No. of alarms

Scroll bar

Reset alarm and Return

Use joystick to scroll if more than two alarms

Refer to Alarm code overview/table for full description on the different alarm codes.

NON AUTO RESET ALARMS

Some alarms is not auto reset, and needs an confirmation from user to be reset. This alarms need reset: No Communication 12, Motor Temp Sensor 13, AC Motor Sensor Fault 29, VFD Fault 34, Warning Low Voltage 35.VFD Modbus Fault 37.

SPECIFIC ALARMS



STOP BUTTON

Pressing the STOP button on a hydraulic panel will activate the dump valve and all hydraulic consumers will be disabled. NB: FOR EMERGENCY USE ONLY

Panel will not run thrusters.
Pressing button below  will mute buzzer alarm at all panels and show the alarm info screen.



ALARM SHOWN ON INACTIVE PANELS!

This screen will be shown on inactive panels if any of the following critical alarms occur:
AC THRUSTER OVERTEMP, AC THRUSTER FAIL

Pressing button below  will mute buzzer alarm at all panels and show the alarm info screen.

POWER MANAGEMENT INFO.

Reduced Power Mode
Thruster output is limited to 50 % thrust by Power Management System.

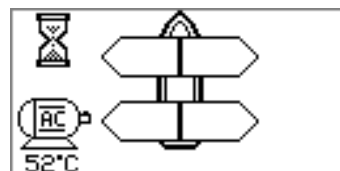
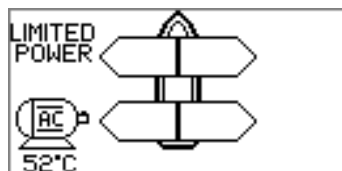

Power Not Available
Power Management System is preventing the thruster from operating.

Symbol alternating with AC motor symbol every 1sec.

Alarm descriptions

"Err. No."	Errors shown in display	"Auto Reset"	"Ext. buzzer activation at Alert Level"	Description	Action
12	No Communication		2 ⁽²⁾ , 3	No communication with device	Check S-Link cables and power connections.
13	Motor Temp Sensor		2 ⁽²⁾ , 3	Motor temperature sensor fail	Check for an open circuit on the temp sensor on the motor
28	AC Motor Overtemp	Yes	2 ⁽²⁾ , 3	"Hydraulic AC motor power pack overtemp. Higher than 120°C/248°F."	Stop running and wait for temperature to drop.
29	AC Motor Sensor Fail		2 ⁽²⁾ , 3	"Hydraulic AC motor power pack temp sensor open circuit"	Check sensor cables.
30	Temperature Warning	Yes	2 ⁽²⁾ , 3 ⁽²⁾	High temperature warning.	Warns that the motor temperature is getting high.
31	Motor Overtemp	Yes	2 ⁽²⁾ , 3	High temperature Alarm.	See SAC manual for more details.
32	VFD Warning	Yes	2 ⁽²⁾ , 3	There is an warning from VFD.	Check VFD for more details.
33	VFD Not Ready	Yes	2 ⁽²⁾ , 3	The VFD is not ready.	Check VFD for more details.
34	VFD Fault		2 ⁽²⁾ , 3	VFD has an Alarm.	Check VFD for more details.
35	Warning Low Voltage	Yes	2 ⁽²⁾ , 3 ⁽²⁾	Low voltage Warning!	
37	VFD Com. Fault		2 ⁽²⁾ , 3	No Modbus communication with VFD	Check VFD Modbus cables and power.

2. Buzzer is only activated when any device is sending thrust on the S-link bus.

Technical specifications and measurements

Description	Minimum	Maximum	Units	Comment
Input voltage	9	31	Volt DC	Powered from S-Link
Current Voltage	20	120	mA	
External Alarm Buzzer Voltage		31	Volt DC	
External Alarm Buzzer Current		500	mA	Internally fused

Description	Value
Operating temperature	-10 to + 60 degrees C.
Storage temperature	-20 to + 70 degrees C.
IP rating front	IPx6
IP rating back	IPx4
Humidity	max 95% RH
EMC tested	Acc. to EN 60533
Weight	215 gr.

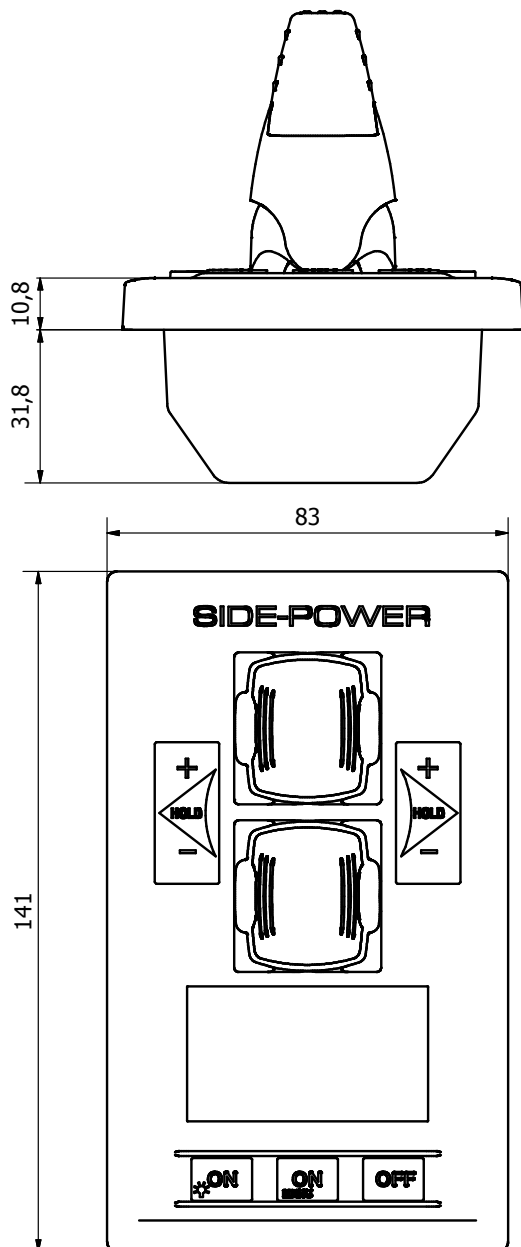

This illustration is for measurements use only. Use external template when mounting.

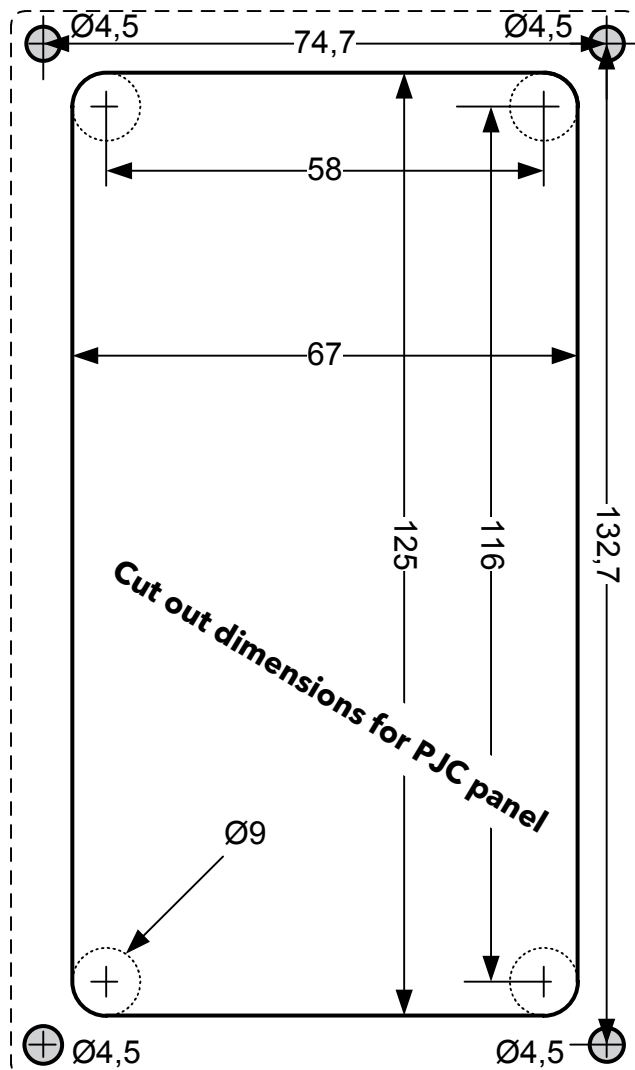

Connections

Connections for optional external buzzer/audible alarm.

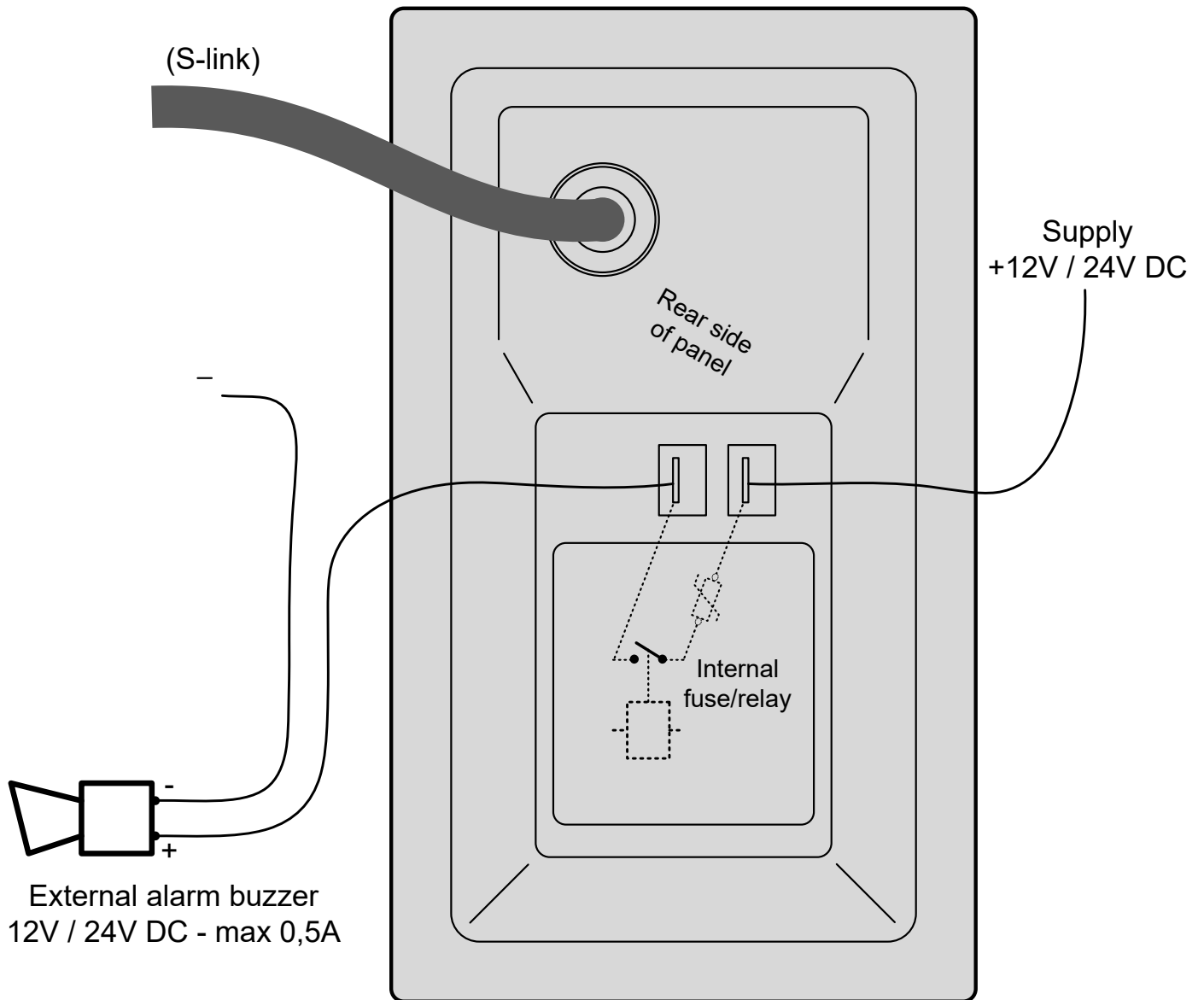

Worldwide sales and service



www.side-power.com



SLEIPNER MOTOR • AS P.O. Box 519 • N-1612 Fredrikstad • Norway
Tel: +47 69 30 00 60 • Fax: +47 69 30 00 70 • www.side-power.com • sidepower@sleipner.no