

TankWatch® 3 Level Monitoring System Instructions

Specifications

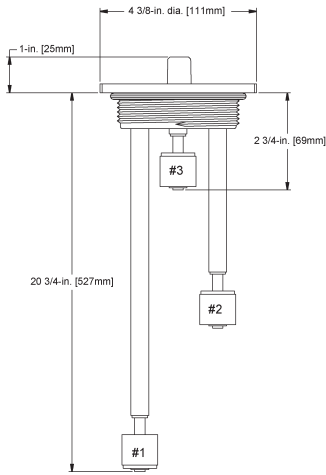

Electrical:
 Maximum Amperage
 12 Volts DC = 1.6 amps resistive
 24 Volts DC = .83 amps resistive
 36 Volts DC = .62 amps resistive

Maximum Tank Pressure: 25 PSI

Materials:
 Float Buna N
 Float Switch Cap PVC
 Float Switch Body ABS
 O-Rings Nitrile
 Adjustable Stems Cross Linked Polypropylene
 Compression Nut Glass Reinforced Polypropylene

Electrical and dimensional specifications subject to change without notice.

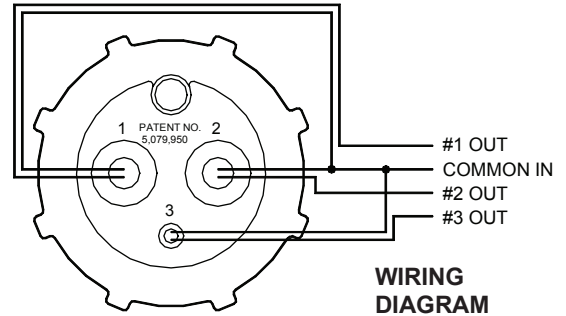

CAUTION: Do not use TankWatch system in a fuel tank. Dropping or rough handling of the cap may result in damage to the float switches.

Installation Instructions

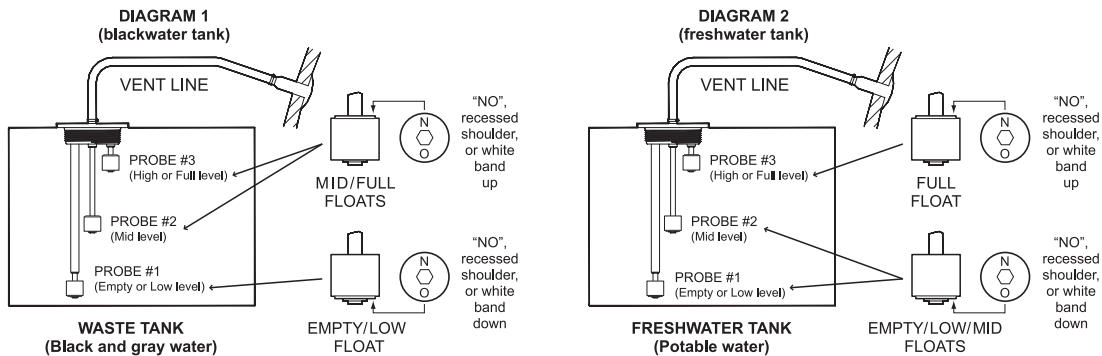

1. The adjustable level indicator cap fits a 3-inch FPT opening. Order part number 230272 if tank is made of rigid material and is not a SeaLand holding tank.
2. Loosen compression nuts on adjustable probes and install cap into tank. Slide #1 probe down until float touches the bottom of the tank. Tighten #1 compression nut and mark probe at the top of the nut with a pen or pencil. Do not cut the probe tubing at this mark. Loosen the compression nut, slide the probe up, and carefully cut the #1 probe tubing 1-5/8 inch (41.3mm) below mark without damaging switch wires. Pull wires through the black wire cover and push probe down into the compression nut until black wire cover touches compression nut.
3. Remove cap from tank and adjust #2 probe for 1/2 full level for gray and black water tanks, or 1/4 full level for freshwater tanks. Tighten compression nut and cut the probe tubing off 3/8-inch (9.5mm) above compression nut without damaging switch wires. Slip black wire cover onto top of stem.
4. To make #1 float switch activate "Empty" light, the float must be positioned with the recessed shoulder, white band, or the letters "NO" at bottom. Remove the C-clip from switch body, flip the float 180 degrees, and replace the C-clip. (See Diagram #1.)
5. The #2 float switch can activate "Mid" light on black and gray water tanks and activate "Low" light on freshwater tanks. The recessed shoulder, white band, or the letters "NO" should be facing up for black and gray water tanks, and down for freshwater tanks. (See Diagram #2.)
6. Route 18-gauge stranded copper wire from indicator panel to level indicator cap. Use quick-disconnect terminals on float switch wires to prevent twisting wires when removing the cap. With cap removed from the tank, connect the wires according to the wiring diagram and test the floats by moving them up and down. Disconnect the wires and install the cap with the O-ring into tank, then reconnect wires.
7. For caps with vents, route 5/8-inch vent hose from the through-hull fitting to the vent connection on the level indicator cap. Use stainless steel hose clamps to secure the vent hose connections.

Parts List

Item	Part No.	Description
1	600342260	Wire cover
2	385310258	Compression nut/washer kit
3	385311250	O-ring cap
4	385230268	Float switch assembly
5	385230958	Tube/adapter assembly
6	600342114 600342115	Adjustable probe cap with vent Adjustable probe cap without vent
7	600342262	Wire cover

NOTE: If replacing float switch assembly (item 4), use O-ring and tighten switch to 8-10 inch-lbs. Overtightening is not necessary and may damage parts.

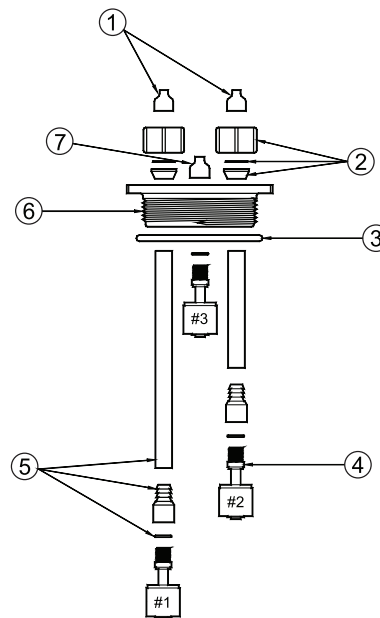

Manufacturer's One-Year Limited Warranty

Dometic Corporation warrants, to the original purchaser only, that this product, if used for personal, family or household purposes, is free from defects in material and workmanship for a period of one year from the date of purchase.

If this Dometic product is placed in commercial or business use, it will be warranted, to the original purchaser only, to be free of defects in material and workmanship for a period of ninety (90) days from the date of purchase.

Dometic reserves the right to replace or repair any part of this product that proves, upon inspection by Dometic, to be defective in material or workmanship. All labor and transportation costs or charges incidental to warranty service are to be borne by the purchaser-user.

EXCLUSIONS

IN NO EVENT SHALL **DOMETIC** BE LIABLE FOR INCIDENTAL OR CONSEQUENTIAL DAMAGES, FOR DAMAGES RESULTING FROM IMPROPER INSTALLATION, OR FOR DAMAGES CAUSED BY NEGLIGENCE, ABUSE, ALTERATION OR USE OF UNAUTHORIZED COMPONENTS. ALL IMPLIED WARRANTIES, INCLUDING ANY IMPLIED WARRANTY OF MERCHANTABILITY OR FITNESS FOR ANY PARTICULAR PURPOSE, ARE LIMITED TO A PERIOD OF ONE YEAR FROM DATE OF PURCHASE.

IMPLIED WARRANTIES

No person is authorized to change, add to, or create any warranty or obligation other than that set forth herein.

Implied warranties, including those of merchantability and fitness for a particular purpose, are limited to one (1) year from the date of purchase for products used for personal, family or household purposes, and ninety (90) days from the date of purchase for products placed in commercial or business use.

OTHER RIGHTS

Some states do not allow limitations on the duration of an implied warranty and some states do not allow exclusions or limitations regarding incidental or consequential damages; so, the above limitations may not apply to you. This warranty gives you specific legal rights, and you may have other rights which vary from state to state.

To obtain warranty service, first contact your local dealer from whom you purchased this product.

Dometic Corporation manufactures a complete line of sanitation products and systems. Write or call the factory to receive free literature on the following products:

- VacuFlush® Toilet Systems
- Dometic® Portable Toilets
- SeaLand® Liquid and Dry Deodorant Products
- SeaLand® Environment-Friendly Holding Tank Deodorant
- SeaLand® brand Toilet Tissue
- SeaLand® Toilet Bowl Cleaner
- SaniGard™ Holding Tank Vent Filter
- OdorSafe® Plus Sanitation Hose and Fittings



Dometic Sanitation Corporation

Big Prairie, OH 44611-0038 USA

330-496-3211

1-800-321-9886 • Fax: 330-496-3097

® Registered; ™ Trademark of Dometic Corporation
© Dometic Corporation