

## Customer service

There is a strong, worldwide network to assist in servicing and maintaining your sanitation system. For the Authorized Service Center near you, please call from 8:00 a.m. to 5:00 p.m. (ET) Monday through Friday.

You may also contact or have your local dealer contact the Parts Distributor nearest you for quick response to your replacement parts needs. They carry a complete inventory for the Dometic product line.

Telephone:	1 800-321-9886 330-439-5550	U.S.A. and Canada International
Fax:	330-496-3097 330-439-5567	U.S.A. and Canada International
Web site:	<a href="http://www.Dometic.com">http://www.Dometic.com</a>	

Dometic is a customer-driven, world-leading provider of leisure products for the RV, automotive, truck and marine markets. We supply the industry and aftermarket with a complete range of air conditioners, refrigerators, awnings, cookers, sanitation systems, lighting, mobile power equipment, comfort and safety solutions, windows, doors and other equipment that make life more comfortable away from home.

Dometic supplies a wide range of workshop equipment for service and maintenance of built-in air conditioners. Dometic also provides specially designed refrigerators for hotel rooms, offices, wine storage and transport and storage of medical products.

Our products are sold in almost 100 countries and are produced mainly in wholly-owned production facilities around the world.

**REVISION A**  
Form No. 600345151 7/17  
©2017 Dometic Corporation

**DOMETIC**  
Dometic Corporation, Sanitation Division  
13128 State Rt. 226, P.O. Box 38  
Big Prairie, OH 44611 USA  
1-800-321-9886 • Fax: 330-496-3097  
[www.Dometic.com](http://www.Dometic.com)

Europe:

### Warranty and Customer Service

Warranty arrangements are in accordance with EC Directive 44/1999/CE and the normal conditions applicable for the country concerned. For warranty or other service, please contact our Dometic service department listed elsewhere in this manual. Any damage due to improper use is not covered by the warranty.

The warranty does not cover any modifications to the product or the use of non-original Dometic parts; the warranty does not apply if the installation and operating instructions are not adhered to and no liability shall be entertained.

### Product Liability

Product liability of Dometic Group and its subsidiary companies does not include damages which may arise from: faulty operation; improper alterations or intervention in the equipment; adverse effects from the environment which may impact the equipment itself or the direct vicinity of the equipment or persons in the area.

To obtain warranty service, first contact your local dealer from whom you purchased this product or go to <http://www.dometic.com> for a dealer near you.

## Warranty and product liability

### North America and Rest of the World:

#### Manufacturer's One-Year Limited Warranty

Dometic Corporation, Sanitation Division warrants to the original purchaser only that this product, if used for personal, family or household purposes, is free from defects in material and workmanship for a period of one year from the date of purchase.

If this Dometic product is placed in commercial or business use, it will be warranted to the original purchaser only to be free of defects in material and workmanship for a period of ninety (90) days from the date of purchase.

Dometic reserves the right to replace or repair any part of this product that proves, upon inspection by Dometic, to be defective in material or workmanship. All labor and transportation costs or charges incidental to warranty service are to be borne by the purchaser-user.

### EXCLUSIONS

IN NO EVENT SHALL DOMETIC BE LIABLE FOR INCIDENTAL OR CONSEQUENTIAL DAMAGES, FOR DAMAGES RESULTING FROM IMPROPER INSTALLATION, OR FOR DAMAGES CAUSED BY NEGLIGENCE, ABUSE, ALTERATION OR USE OF UNAUTHORIZED COMPONENTS. ALL IMPLIED WARRANTIES, INCLUDING ANY IMPLIED WARRANTY OF MERCHANTABILITY OR FITNESS FOR ANY PARTICULAR PURPOSE, ARE LIMITED TO A PERIOD OF ONE YEAR FROM DATE OF PURCHASE.

### IMPLIED WARRANTIES

No person is authorized to change, add to, or create any warranty or obligation other than that set forth herein. Implied warranties, including those of merchantability and fitness for a particular purpose, are limited to one (1) year from the date of purchase for products used for personal, family or household purposes, and ninety (90) days from the date of purchase for products placed in commercial or business use.

### OTHER RIGHTS

Some states do not allow limitations on the duration of an implied warranty and some states do not allow exclusions or limitations regarding incidental or consequential damages; so, the above limitations may not apply to you. This warranty gives you specific legal rights, and you may have other rights which vary from state to state.

To obtain warranty service, first contact your local dealer from whom you purchased this product or go to <http://www.dometic.com> for a dealer near you.



EN Vacuum generator instruction manual



**JW Series  
VacuFlush®  
Vacuum  
Generator**

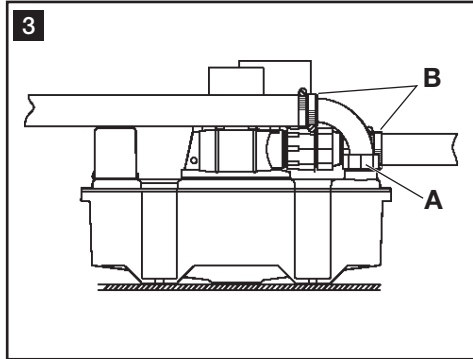
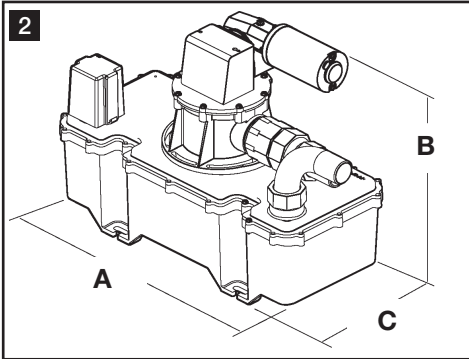
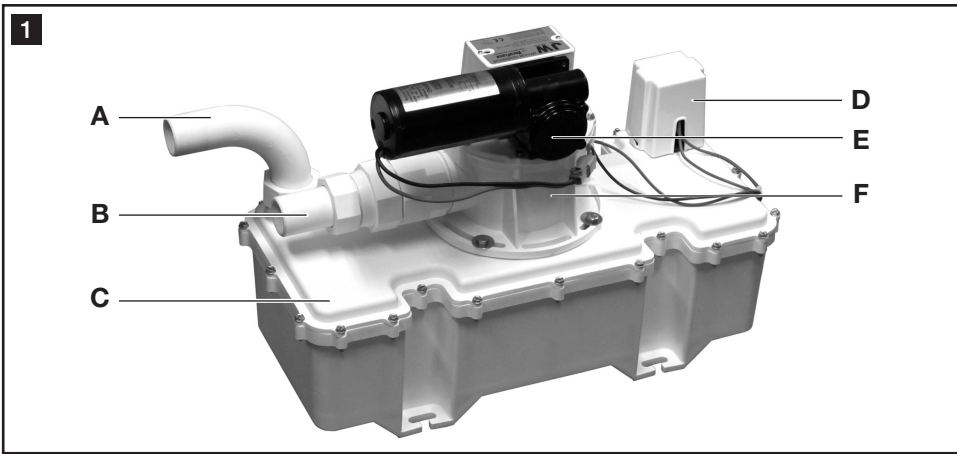

## Components (fig. 1)

Ref.	Description	Ref.	Description
A	Inlet fitting	D	Vacuum switch
B	Outlet fitting	E	Vacuum pump motor
C	Vacuum tank	F	Vacuum pump body

Refer to complete parts list (packed separately) for additional information.

## Dimensions (fig. 2)

Ref.	Dimension
A	20.125 in. / 511 mm
B	14 in. / 356 mm
C	9.125 in. / 232 mm

## Installation



**Note**  
Two-toilet VacuFlush systems require a vacuum generator for each toilet.

### General guidelines

- Vacuum generator must be installed **horizontally only**.
- The vacuum generator can be located up to 50 feet (15.2 m) from the VacuFlush toilet, and 20 feet (6.1 m) from the holding tank or other waste destination.
- The vacuum generator inlet must not be located more than 6 feet (1.8 m) higher than the toilet discharge outlet.
- The maximum head pressure on the discharge of the vacuum generator must not exceed 6 feet (1.8 m).
- To minimize standing sewage in discharge hose, position vacuum generator inlet at same level or lower than toilet outlet where possible.

### Installation and plumbing

- Make sure the vacuum generator is properly located before proceeding. Place the vacuum generator on flat surface. Position as needed. Using a center punch, mark the four slotted holes in the pump feet. Remove vacuum generator.
- Using a 3/16-inch (5 mm) drill bit, drill the four mounting holes. Use #14 wood screws and washers to secure vacuum generator.
- Position pump body (fig. 1 F) to accommodate plumbing layout, if necessary, by loosening four fasteners that hold pump onto vacuum tank, rotating pump body to desired position, and retightening fasteners.
- Spin-nut connections on inlet and outlet fittings allow easy installation and positioning of hoses. After positioning inlet fitting in proper direction to accept inlet hose from toilet, **make sure to tighten spin-nut 1/2-turn past hand-tight with wrench** (fig. 3 A).

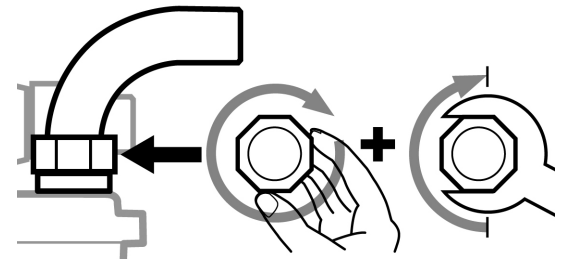

**Note**  
Use two hose clamps for each hose connection (fig. 3 B).



**Note**  
Make sure to connect toilet discharge hose to inlet fitting of vacuum generator.

## Notes on using these instructions



**Caution!**  
**Safety Instruction:** Failure to observe this instruction can cause material damage and impair the function of the device.



**Note**  
Supplementary information for operating the device.

fig. 1 A: This refers to an element in an illustration. In this example, item A in figure 1.

## General safety instructions

The manufacturer will not be held liable for claims for damage resulting from the following:

- Faulty assembly or connection
- Damage to the unit from mechanical influences, misuse or abuse
- Alterations to the unit without express written permission from the manufacturer
- Use for purposes other than those described in the operating manual

### Warnings

The following statements must be read and understood before installing, servicing and/or operating this product. Modification of this product may result in property damage.

Dometic recommends that a qualified technician or electrician install or service this product. Equipment damage, injury to personnel or death could result from improper installation. DOMETIC ACCEPTS NO RESPONSIBILITY OR LIABILITY FOR DAMAGE TO EQUIPMENT, OR INJURY OR DEATH TO PERSONNEL THAT MAY RESULT FROM IMPROPER INSTALLATION, SERVICE OR OPERATION OF THIS PRODUCT.

## Intended use

The Dometic JW series vacuum generator creates the powerful vacuum of a VacuFlush toilet system. When the toilet is flushed, the vacuum in the discharge line pulls the toilet contents into the vacuum generator, which then propels the effluent to a holding tank or other waste treatment device.

### Benefits

**Versatile installation.** Powerful vacuum pump allows toilet to be located up to 50 ft. (15.2 m) away and 20 ft. (6.1 m) from holding tank or other waste destination.

**Automatic “full tank” shut-down.** When installed with holding tank that includes a “full tank” level indicator, an automatic shut-down relay will stop electrical power to the vacuum generator when the holding tank level reaches “full.” This prevents holding tank overfill which can cause damage to the toilet system.

**Easy maintenance.** Two-piece design allows easy access to vacuum tank interior if required.

## Specifications

### Materials

Pump body: glass-filled polypropylene  
Pump bellows: engineered PP/PE resin  
Duckbill valves: EPDM

Vacuum tank and fittings: glass-filled polypropylene

### Electrical Specifications

Model	Voltage (DC)	Power Draw (amp average)	Fuse/breaker	Flow (GPM/LPM)	Wire size	Weight (kg/lbs.)
VG4-12	12	6	10	5.1 / 19.3	follow local codes*	15.1 / 6.9
VG4-24	24	3	5	5.1 / 19.3	follow local codes*	15.1 / 6.9

\* For marine applications follow ABYC wiring recommendations. Specifications subject to change without notice.



**CAUTION! ELECTRICAL HAZARD**  
**DO NOT CONNECT JW SERIES VACUUM GENERATOR DIRECTLY TO STANDARD RESIDENTIAL WIRING SYSTEM.** JW series vacuum generator operates on 12 V DC or 24 V DC through a 10-amp or 5-amp circuit (see Electrical Specifications chart, above). For residential use, this product must be connected to a minimum 12-amp power converter with 12 V DC electrical output.

## Wiring

- Wire vacuum generator according to diagram below and Electrical Specifications in VacuFlush toilet manual.
- Pre-wired connectors (if applicable) can be cut off to complete wiring.
- Use stranded copper wire. Protect wires with grommets or other protective devices at holes and sharp edges.
- Do not overfuse. Overfusing the vacuum generator will result in warranty invalidation.



**Caution – Pump starts automatically.**  
Turn off power before making final electrical connection or servicing.

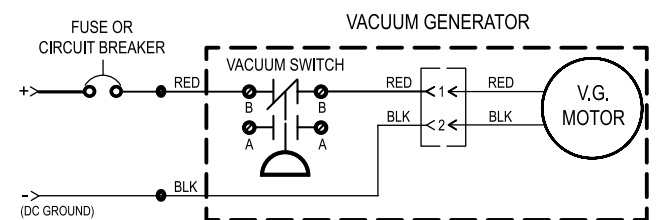

**Note**  
If vacuum generator connects to electronic-flush VacuFlush toilet, refer to VacuFlush toilet wiring diagram for complete information.

### Vacuum testing

- Prime pump with water before performing vacuum test. If vacuum generator is part of compost system, make sure discharge hose from vacuum generator is not connected to compost unit during priming process.
- POSITIVE PRESSURE TESTING IS NOT RECOMMENDED.** JW series vacuum generator is designed to seal with negative pressure (vacuum), and will not hold positive pressure.

## Operation

When a VacuFlush toilet is flushed, vacuum pressure created by the vacuum generator pulls waste from the toilet to the vacuum generator. The increase of ambient pressure in the vacuum tank causes the vacuum switch (fig. 1 D) to turn on power to the vacuum generator. The vacuum pump begins to create vacuum and push the effluent in the discharge line to the holding tank or other destination. After vacuum is restored in the discharge system (about 60-90 seconds, depending on the installation), the vacuum switch shuts off electrical power, and the toilet system is ready for the next flush.



**Caution!**  
Vacuum pump starts automatically. Turn off electrical power before servicing.