

isotemp

Isotemp Basic, Slim & Slim Square

Marine water heater – Scaldabagno nautico – Marine
Warmwasserber Dieter – Chauffe-eau marine – Marin
varmvattenberedare – Calentador de agua náutico – Marine
tapwaterboiler – Морской водонагреватель



GB - Operators Manual
IT - Manuale istruzioni
D - Bedienungsanleitung
F - Manuel d'utilisation
S - Bruksanvisning
ES - Manual de operación
NL - Gebruiksaanwijzing
RU - Инструкция для пользователя

indel
Webasto
Marine

Zona Artigianale sn
I-47866 S. Agata Feltria (RN) Italy
Tel. +39 0541 848 030
Fax +39 0541 848 563

E-mail: info@indelwebastomarine.com
www.indelwebastomarine.com

Notes:

Table of contents

1. Safety instructions
2. Locating the tank
3. Mounting
4. Connections
 - 4.1 Fittings
 - 4.2 Hoses
 - 4.3 Connections to engine
 - 4.4 Freshwater system connections
 - 4.5 Electrical connections
5. Start up/Test
6. Maintenance
 - 6.1 Pressure relief device / Safety valve
 - 6.2 Winterization
 - 6.3 Replacing thermostat
 - 6.4 Replacing heater element
7. Double heat exchanger
8. Technical data
 - 8.1 Basic
 - 8.2 Slim
 - 8.3 Slim Square

1 Safety instructions

This manual has been compiled to help you to operate your water heater with safety and pleasure. It contains information about operation and maintenance.

Please read it carefully and make yourself familiar with the product and keep this manual in a safe place on board.

It is important that your water heater is correctly installed and maintained. During the winter period when the unit is not being used it is essential that it is drained to avoid risk of damage due to freezing. Every single water heater is individually pressure tested prior to delivery and carries a two year factory warranty in respect of defects in material and/or manufacture.

Indel Webasto Marine S.r.l. accepts no responsibility or liability for damage to equipment, injury to personnel that may result from improper installation or operation of this product.



Danger!

All electrical installations on board must be carried out by authorized specialists. The water heater must be properly grounded to the AC system.



Danger!

Always use recommended wire size, fuse/circuit breaker and a GFC-breaker.



Warning!

If the supply cord is damaged, it must be replaced by the manufacturer, its service agent or similarly qualified person in order to avoid a hazard.



Warning!

Do not connect the heater element to the power net until the water heater tank is filled with water.



Warning!

Only pure and drinkable freshwater must be used, salt (chlorides) must be less than 50 mg/Lt and electrical conductivity must be less than 200 μ S/cm. This is a condition for the validity of the warranty because if this is not respected the stainless steel in the tank can be damaged.



Warning!

Risk of scalding, the hot water in the water heater will be as hot as the engine.

Caution!

Consider the chapter 4.5 electrical connections regarding risk of corrosion in connection with shore power.

Caution!

Follow carefully the engine manufacturers instructions regarding connection to the engine cooling system.

Caution!

When there is a risk of freezing see chapter 6.2.



Warning!

This appliance can be used by children aged from 8 years and above and persons with reduced physical, sensory or mental capabilities, or lack experience and knowledge, if they have been given supervision or instruction concerning use of the appliance in a safe way and understand the hazards involved. Children shall not play with the appliance. Cleaning and user maintenance shall not be made by children without supervision.

Environment:

This appliance is marked according to the European directive 2012/19/EU on Waste Electrical and Electronic Equipment (WEEE).

By ensuring this product is disposed of correctly, you will help prevent potential negative consequences for the environment and human health, which could otherwise be caused by inappropriate waste handling of this product.

The symbol  on the product, or on the accompanying documents indicates that this appliance may not be treated as household waste.

Instead it should be handed over to the applicable collection point for the recycling of electrical and electronic equipment. Disposal must be carried out in accordance with local environmental regulations for waste disposal. For more detailed information about treatment, recovery and recycling of this product, please contact your local city office, your household waste disposal service or the shop where you purchased the product.

2 Locating the tank

The water heater can be mounted anywhere on the vessel as long as the connections to the engine heat exchanger are below the engine header tank (Fig. 1). It is best to keep the length of the heat exchanger hoses short to keep flow resistance and heat loss to a minimum. In many installations the tank heat exchanger is simply connected in series with the engine coolant circuit. In some installations it is connected in parallel with a flow restrictor/diverter.

The choice depends on the specific recommendations of the engine manufacturer and or installer. Please consult the manufacturer or dealer of your engine for any recommendations they may have for connecting to the engine cooling system.

In case the tank has to be placed above the engine header tank, the engine water hose circuit must be equipped with an air bleeder valve on the highest point. This is available as an extra equipment.

Principal connection diagram

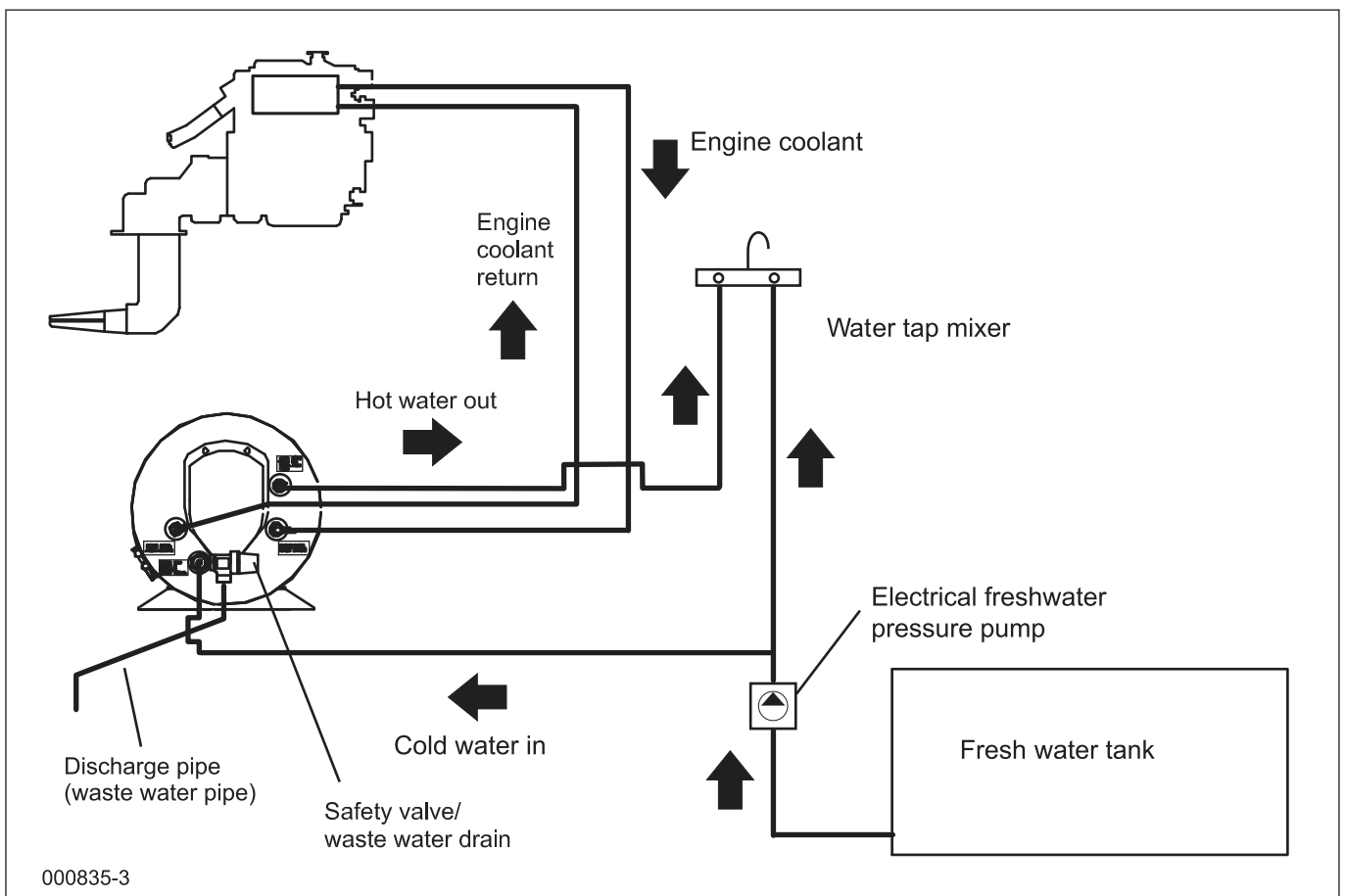

Fig. 1

3. Mounting

The Isotemp Basic, Slim & Slim Square water heaters are designed to give excellent performance when mounted horizontally and vertically. The drain / safety valve must always be at the lowest point. The mounting brackets can be adjusted to the side on Basic and Slim for mounting the tank on a bulkhead. Always mount the tank to a suitable shelf or bulkhead and keep in mind the extra weight of the tank when it is full of water. See alternative mounting positions fig. 2.

Slim Square can be standing or laying down flat, or placed in other alternative positions as seen in fig. 7. Fig. 3 shows Basic, fig. 4 Basic with double coils, fig. 5 – Slim and fig. 6 – Slim Square water hose connections.

It is to prefer to keep about 30 cm (1 ft.) free space in front of the water heater for future service measures.

Isotemp Basic & Slim

Mounting alternatives, horizontal or vertical.

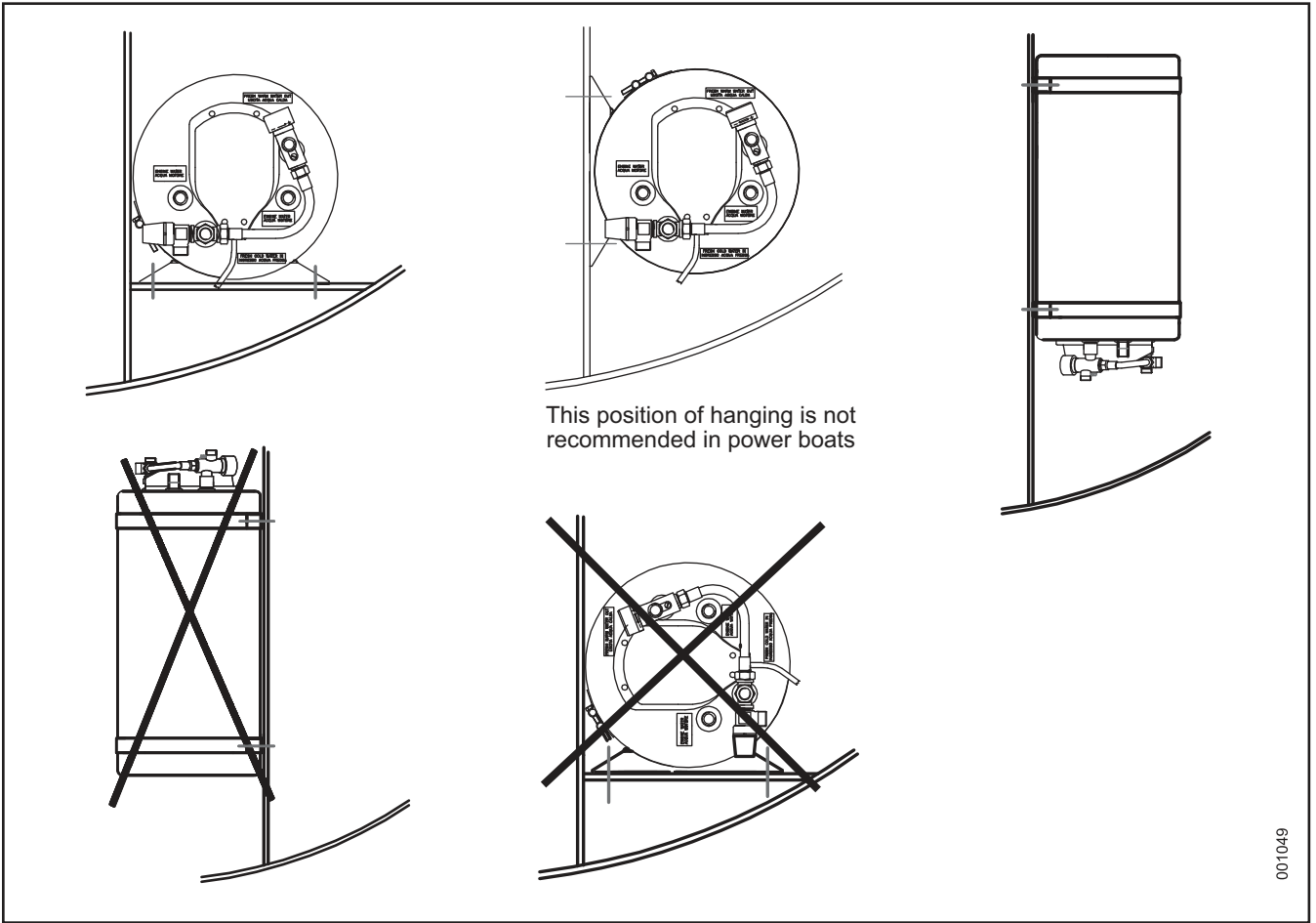

Fig. 2

Isotemp Basic without and with thermostat mixer valve

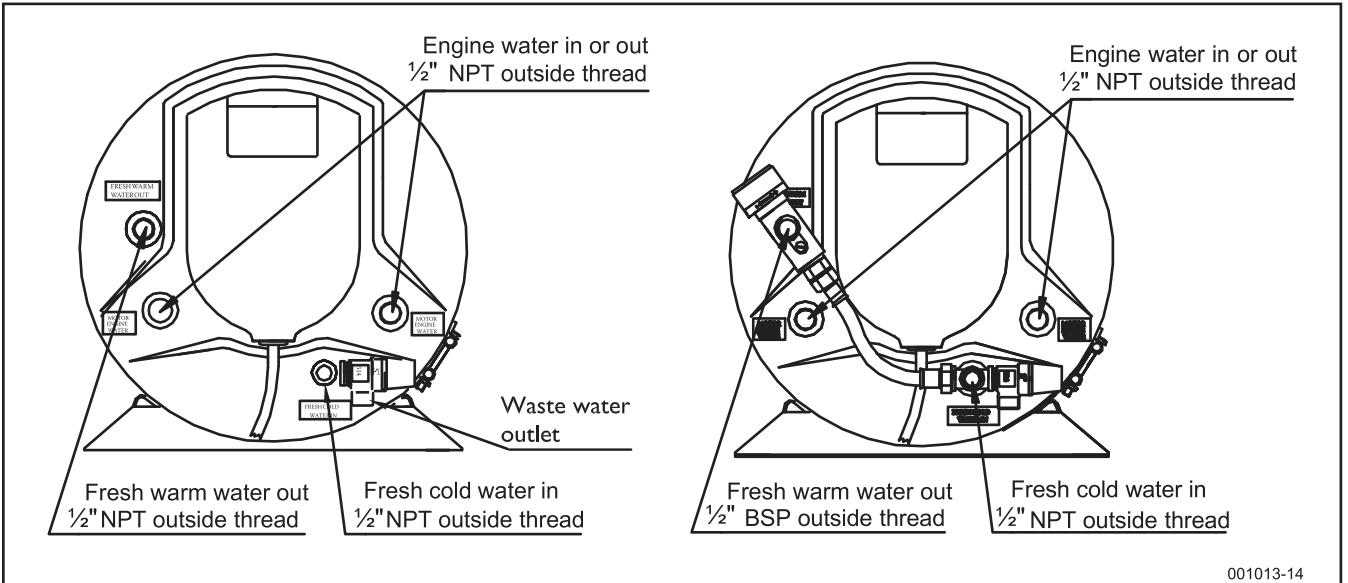

Fig. 3

Isotemp Basic with double coils, without and with thermostat mixer valve

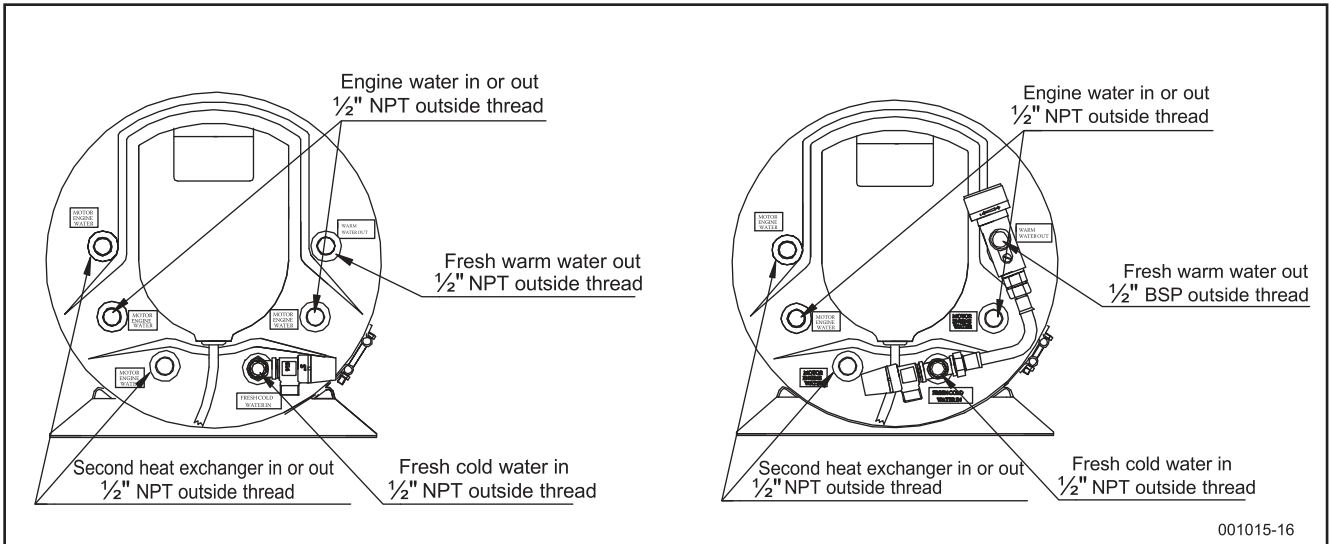

Fig.4

Isotemp Slim without and with thermostat mixer valve

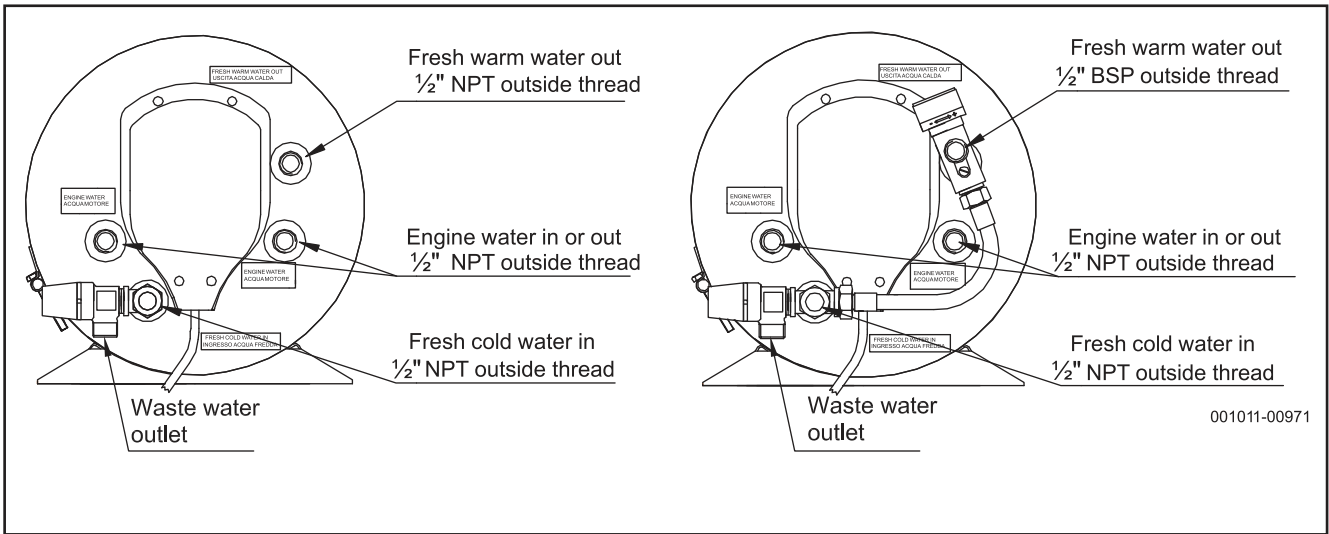

Fig. 5

Please Note:

Hose nipples with straight 1/2 inch BSP threads fits also to 1/2 inch NPT outside threads.

Slim Square without and with thermostat mixer valve

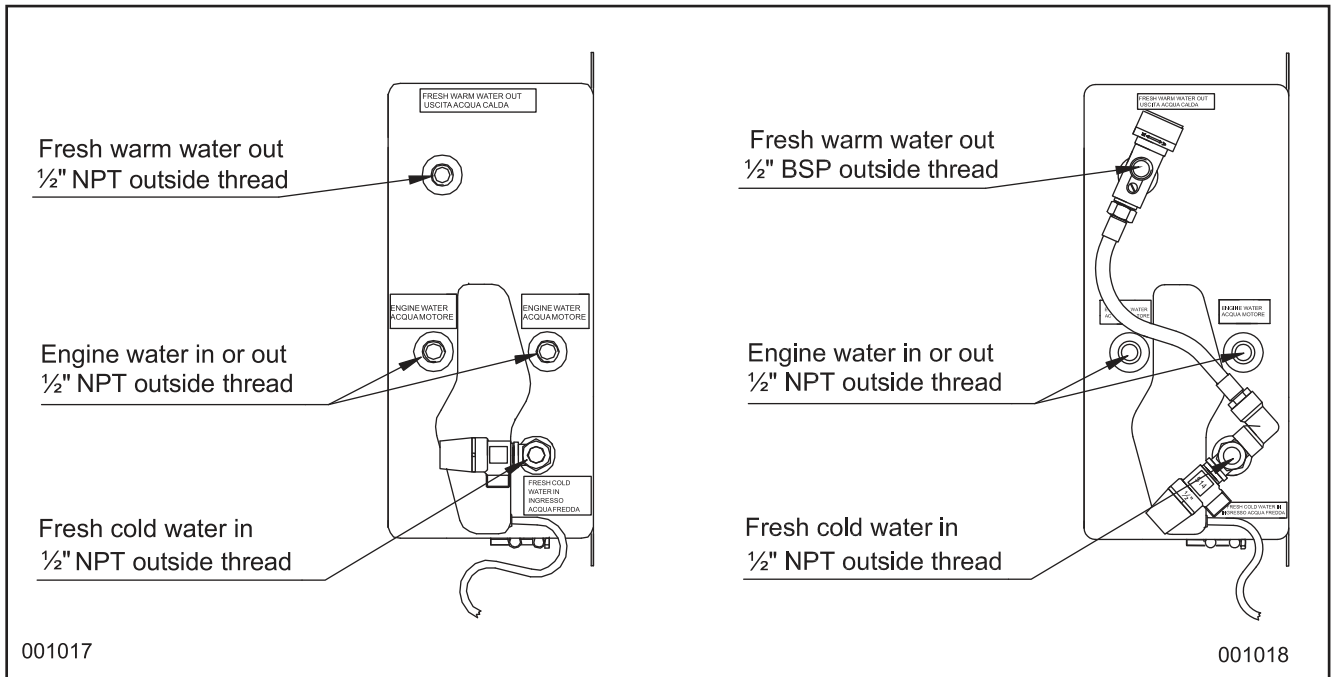

Fig. 6

Slim Square

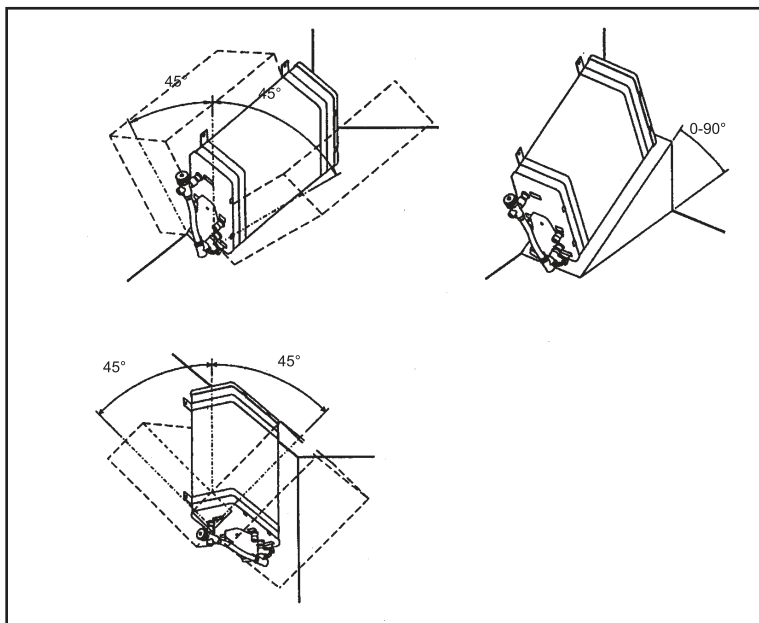

Fig. 7

Slim Square alternative mounting positions. Remember, safety valve always at the lowest position.

4 Connections

4.1 Material:

Use only fittings and accessories made of non-corrosive material such as brass or stainless steel. Avoid plastic fittings on the water heater depending on the heat, unless they are specially made for this purpose. This is important, a leak in this area can cause a sudden engine overheat as well as a dangerous hot water spray.

4.2 Hoses:

For the engine connections, use heat resistant (100 °C / 210 °F) reinforced rubber hoses, resistant to anti-freeze and pressure approved for 5 bar / 70 psi. For the fresh water, cold inlet and warm outlet, use heat resistant fresh water hoses (food industry quality). They shall be rated 8 bar / 115 psi. Fasten the hoses carefully with hose clamps. Seal the threaded connections with e.g. Loctite 577 or Bondline T777. Flare nipples with thread G1/2" (1/2" BSP) fits the connectors on the water heater.

4.3 Connections to engine

(see connection diagram, fig. 1):

The water heater may be used with fresh water cooled engines. The flow of cooling water from the engine through the water heater should be at least 2 litres/min. If the boat has two engines, connect the water heater to

one engine only. When two water heaters are mounted, they shall be connected in parallel.

Connection to the engine shall be done with min. 5/8" / 16 mm hoses and adaptors to avoid restrictions. See the instructions in the engine operators manual, regarding hose connection points.

In the engine cooling circuit feeding the heat exchanger should be installed monitoring and control device with appropriate temperature setting which during normal operation to prevent the activation of the thermal cut-out of the electric heating element.

4.4 Freshwater connections

(see connection diagram, fig 1):

The water heater is fed with fresh water from the electrical pressure pump in the water system. Max working pressure for the pump: 3.8 bar / 55 psi.

Please note that the pressure relief valve on the tank is set to 7.0 bar /100 psi. Fresh water is taken in at the safety valve. The hot water outlet, which also vents the water heater, should be connected to a mixer tap at the sink and/or basin outlet.

Warning! Please note that the hot water is as hot as the engine, there is a risk of scalding! Mix in cold water at the taps. In case the water heater is equipped

with a tempering valve (thermostatic mixing valve) a proper temperature of the warm water can be set on the adjustable tempering valve to avoid scalding. The temperature can be set between 38 and 65 °C / 100 and 150 °F.

The discharge pipe (waste water hose) connected to the pressure-relief device (safety valve) must be installed in continuously downward direction, in a frost-free environment and must always have a free outlet. There must be no valves or skin fittings, fitted to the waste water hose. A small quantity of water can drain from the relief valve when the tank is heated. The water expands during heating. This is a normal situation and indicates the system works properly.

4.5 Electrical connections

(see wiring diagram fig. 8):

All internal connections are made in the factory. The power supply cable is fitted with a standard EU plug, which should be fitted to a correctly installed socket.

This socket, as all "high-voltage" installations on board, must be carried out by an authorized electrician to fulfill valid safety regulations. The water heater is designed to meet regulations in this field. The shore power system installation on board, must include a ground fault circuit interrupter.

When leaving the boat for longer periods, always unplug the cable connector from the socket. This should be done even if the shore power system is shut off, as there can be a difference in the electrical system, between the earth and the sea-water earth of the boat. This can seriously damage the water heater or the heating element.

Installation of an insulation transformer in the shore power equipment eliminates any risk of galvanic corrosion via the shore power connection.

Always unplug the heater and/or turn off all circuit breakers and disconnect shore power connections before removing the connection cover. The electrical circuit is controlled by a service thermostat set to 75°C / 167°F and a double overheat protector that is set to 96°C / 205°F. If the overheat protector trip, it has to be manually reset. This is done by pressing the small knob on top of the overheat protector.

See section 6.3.

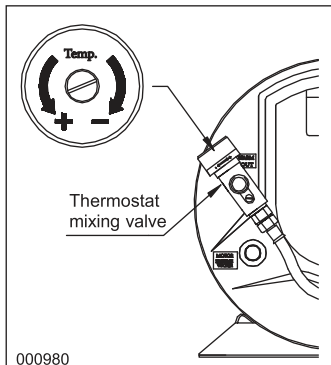

Wiring diagram

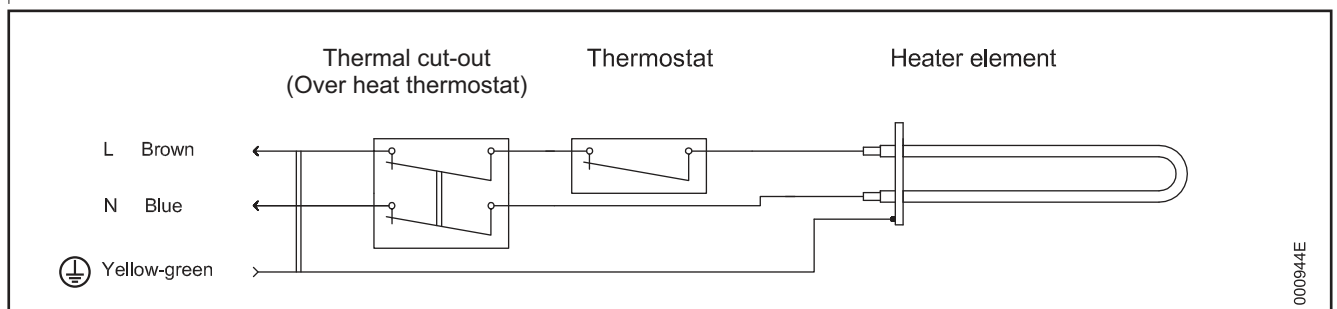

Fig. 8

5 Start up/test

Fill the hot water tank by turning on the water pressure pump and opening a hot water tap to allow air to bleed out of the hoses and / or plumbing. Check the drain and pressure relief valve by pushing the lever. Water will flow into the drain hose. Make sure the drain hose is not blocked or closed. Pull the lever back to closed position. Start the engine to check the circulation of the coolant.

It will be necessary to add coolant to the system to compensate for the additional volume of the exchanger and hoses. Check for air locks in the connecting hoses and raise and lower these as necessary to clear the air from the hoses before securing the hoses in place. Lastly plug in the tank and turn on the circuit breaker. Check for proper operation.

6 Maintenance

6.1 Pressure relief device / Safety valve

The pressure-relief device is to be operated regularly to remove lime deposits and to verify that it is not blocked.

6.2 Winter drain

When there is a risk of freezing the tank must be drained.

This is done by taking off the hot water hose or opening the air bleeder screw mounted on the mixing valve, if such a valve is mounted. Take the air screw away completely, and open the drain valve by turning the black knob anticlockwise one snap on the safety valve. The valve is closed again by tuning further one step anticlockwise.

If the engine is raw-water cooled the heat exchanger must also be drained by removing the hoses and blowing air into the coils to drain any water. The tank can now be safely left in the vessel over the winter. When leaving the vessel for longer periods, it is recommended to take out the power cord to eliminate the risk of stray current from the shore power earth connections.

6.3 Replacing | re-setting thermostat

Warning: Be sure to turn power off first!

The immersion heater is 230 V~ or 115 V~. The thermostat equipment has an integrated working thermostat and a double thermal cut-out (overheat protection thermostat). This is manually re-settable, by pushing the pin on the top of the thermostat. (See fig. 10). Also check why the thermal cut-out initially tripped before re-connection the power supply.

Turn off the power! Pull out the cable plug. Take off the front plastic cover (Basic 2, Slim 4 screws and Square 3 screws). Reset overheat thermostat.

Replacing thermostats: Pull off the cable shoes after having noticed their positions. Thermostat sensor ends are put into a tube on the heater element fastening flange. Pull them out. Unscrew fastening screws for the thermostats. Mount new thermostats in opposite order. Be sure sensor ends are properly put into the tube.

When leaving the boat for longer periods, it is recommended to disconnect the power supply cable plug. This should be done even if the shore power system is shut off, as there can be a difference in the electrical system, between the earth lead and the salt water earth of the boat. This can seriously damage the water heater and/or engine with propulsion equipment.

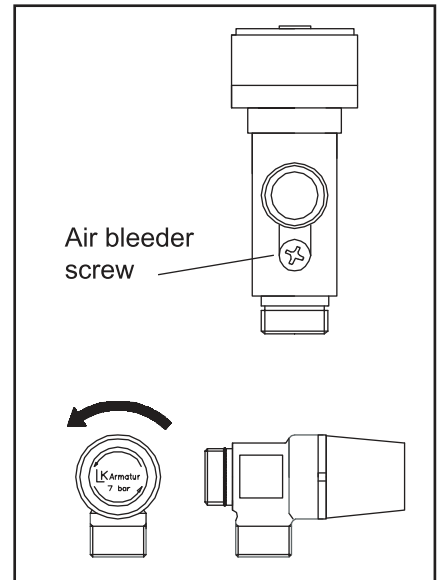

Fig. 9

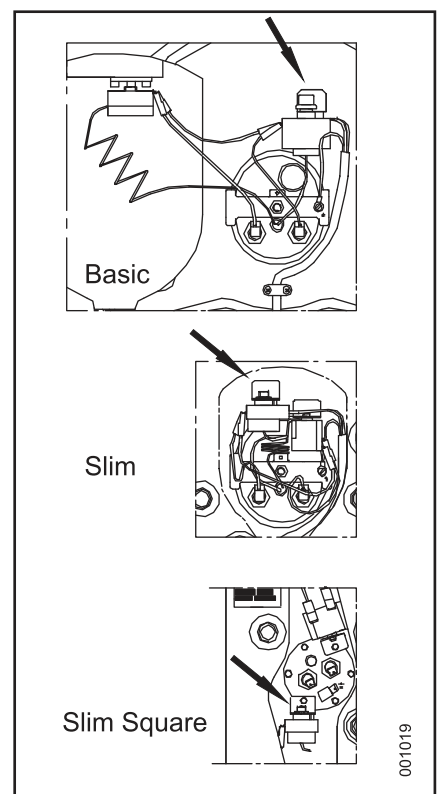

Fig. 10

6.4 Replacing heater element:

Warning! Be sure to turn power off first!

Drain the tank from water.

Basic and Slim

Take off the plastic cover, unscrew the two screws at the sides and push the cover downwards. Dismantle the thermostat and the overheat protector from their brackets for better access on the Slim model.

On Basic they can be left in position during the operation.

Pull off the wires from the heating element tabs.

Loosen the centre nut, fig. 11-A and take off the support, fig. 11-B. Put on the nut again on the centre bolt for easier handling, easier to grab by hand.

Push off the mounting flange and rubber gasket inwards, it will come out together with the heater element unit. Turn the heater element unit 90° to the left, the wire tabs shall point to the right.

Twist the unit until the inner end hits the tank to the left.

Pull out the heater element unit through the hole with the left side first.

Unscrew the heater element from the mounting flange.

Mount the new heating element with new seal rings and a new big rubber gasket in the opposite order to the description above. The inner end of the heating element shall point slightly downwards after assembly.

Slim Square

The heating element unit is on the Square model fastened by six screws on a flange which is fastened into the tank. It has a rubber gasket. See fig. 11

First, pull off the wires from the heating element tabs.

Loosen all six screws, the heating element unit including the flange can be pulled out. Note the position of the flange.

The heating element is fastened on the flange with nuts.

Unscrew the heating element from the mounting flange.

Mount the new heating element with new seal rings and a new big rubber gasket in the same position as before.

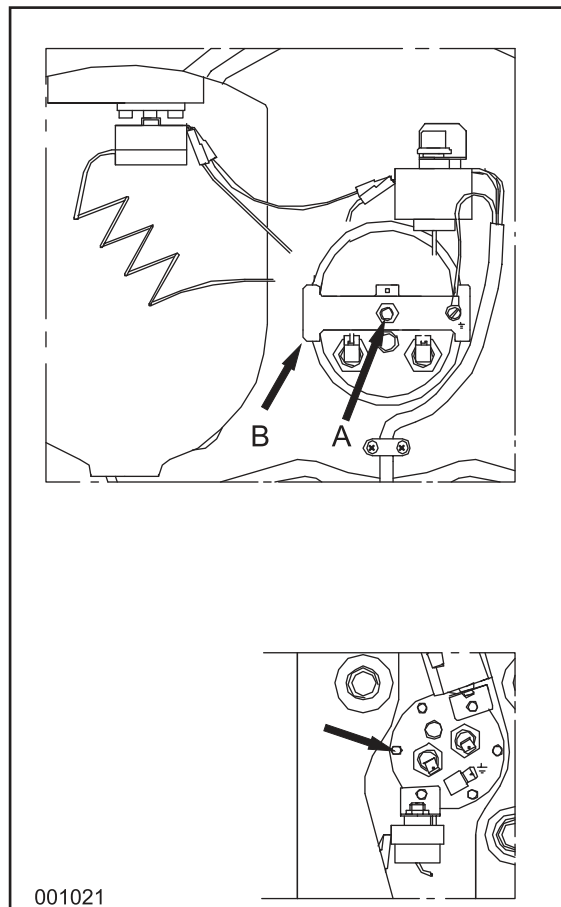

Fig. 11

7. Double heat exchanger, Basic 40 & 75 litres.

Double heat exchanger water heaters have connections for the second heat exchanger located also on the front, side by side with ordinary heat exchanger connections.

See fig. 4

Replacement of the heating element is made the same way as the description above.

8. Technical data

8.1 Basic

Type	Volume lit.	Weight kg / lbs	Heater element	Heater element options	Thermostat mixer valve
602431B000000	24	12.5 / 27.5	230V-750W	115V-750W	-
602431B000003	24	12.5 / 27.5	230V-750W	115V-750W	X
602431BD000000 (Double coils)	24	13 / 29	230V-750W	115V-750W	-
602431BD000003 (Double coils)	24	13 / 29	230V-750W	115V-750W	X
603031B000000	30	13.5 / 30	230V-750W	115V-750W	-
603031B000003	30	13.5 / 30	230V-750W	115V-750W	X
604031B000000	40	15.5 / 34	230V-750W	115V-750W 115V-1200W * 230V-1200W *	-
604031B000003	40	15.5 / 34	230V-750W	115V-750W 115V-1200W * 230V-1200W *	X
604031BD000000 (Double coils)	40	16 / 35	230V-750W	115V-750W 115V-1200W * 230V-1200W *	-
604031BD000003 (Double coils)	40	16 / 35	230V-750W	115V-750W 115V-1200W * 230V-1200W *	X
605031B000000	50	17 / 37.5	230V-750W	115V-750W 115V-1200W * 230V-1200W * 230V-2000W *	-
605031B000003	50	17 / 37.5	230V-750W	115V-750W 115V-1200W * 230V-1200W * 230V-2000W *	X
607531B000000	75	24.5 / 54	230V-750W	115V-750W 115V-1200W * 230V-1200W * 230V-2000W *	-
607531B000003	75	24.5 / 54	230V-750W	115V-750W 115V-1200W * 230V-1200W * 230V-2000W *	X
607531BD000000 (Double coils)	75	25 / 55	230V-750W	115V-750W 115V-1200W * 230V-1200W * 230V-2000W *	-
607531BD000003 (Double coils)	75	25 / 55	230V-750W	115V-750W 115V-1200W * 230V-1200W * 230V-2000W *	X

* – Heating elements 1200W and 2000W are applicable in horizontal position of the appliance only!

Dimensions: See fig 12
 Material: Heat exchanger coil, storage tank and connections: stainless steel AISI 316
 Outside cover and mounting brackets: Stainless steel AISI 304
 Heater element: Nickel plated copper
 Insulation: Polyurethane
 Safety valve: 7 bar / 100 psi

Dimensions Basic

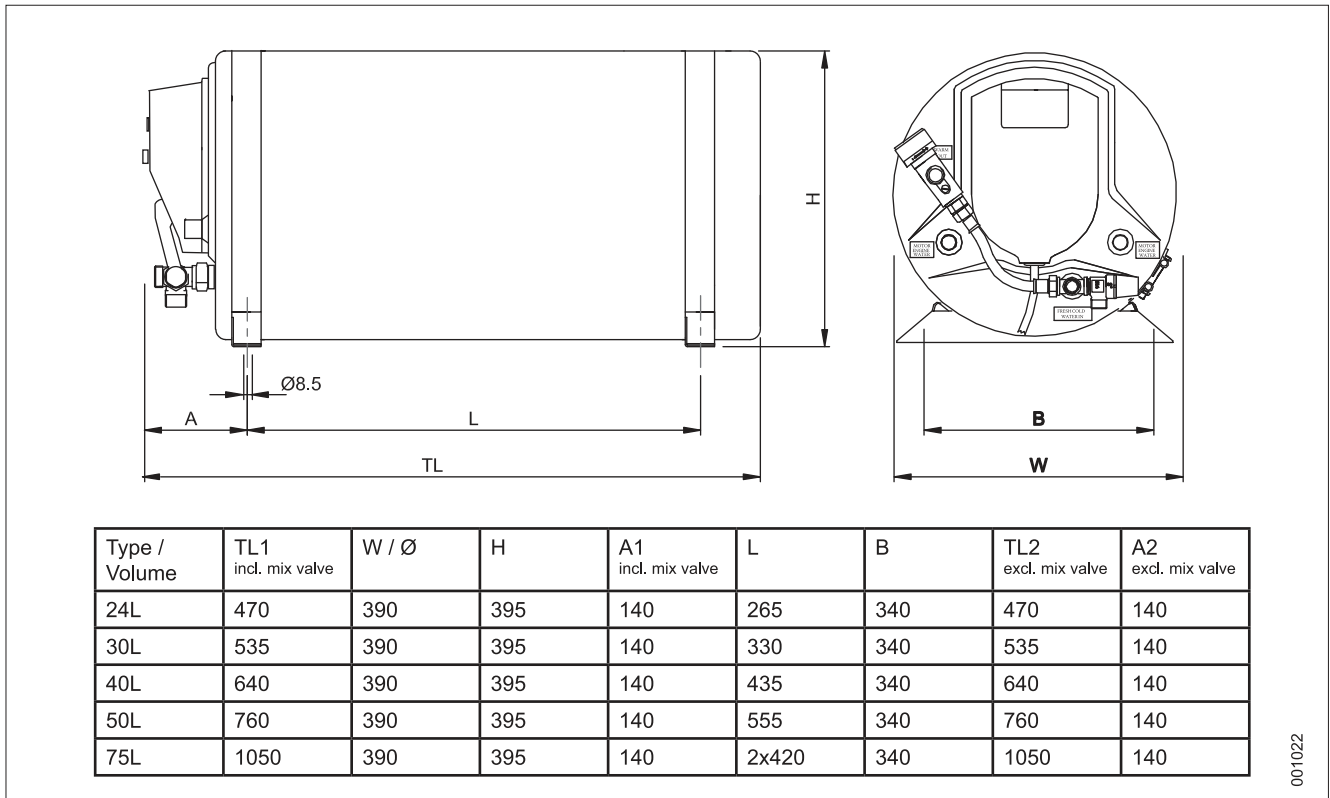

001022

Fig. 12

8.2 Slim

Type	Volume lit.	Weight kg / lbs	Heater element	Heater element option	Thermostat mixer valve
601531S000000	15	9 / 20	230V-750W	115V-750W	-
601531S000003	15	9 / 20	230V-750W	115V-750W	X
602031S000000	20	10.5 / 23	230V-750W	115V-750W 115V-1200W * 230V-1200W *	-
602031S000003	20	10.5 / 23	230V-750W	115V-750W 115V-1200W * 230V-1200W *	X
602531S000000	25	12 / 26.5	230V-750W	115V-750W 115V-1200W * 230V-1200W * 115V-2000W * 230V-2000W *	-
602531S000003	25	12 / 26.5	230V-750W	115V-750W 115V-1200W * 230V-1200W * 115V-2000W * 230V-2000W *	X

* – Heating elements 1200W and 2000W are applicable in horizontal position of the appliance only!

Dimensions: See fig 13
 Material: Heat exchanger coil, storage tank and connections: stainless steel AISI 316
 Outside cover and mouting brackets: Stainless steel AISI 304
 Heater element: Nickel plated copper
 Insulation: Polyurethane
 Safety valve: 7 bar / 100 psi

Dimensions Slim

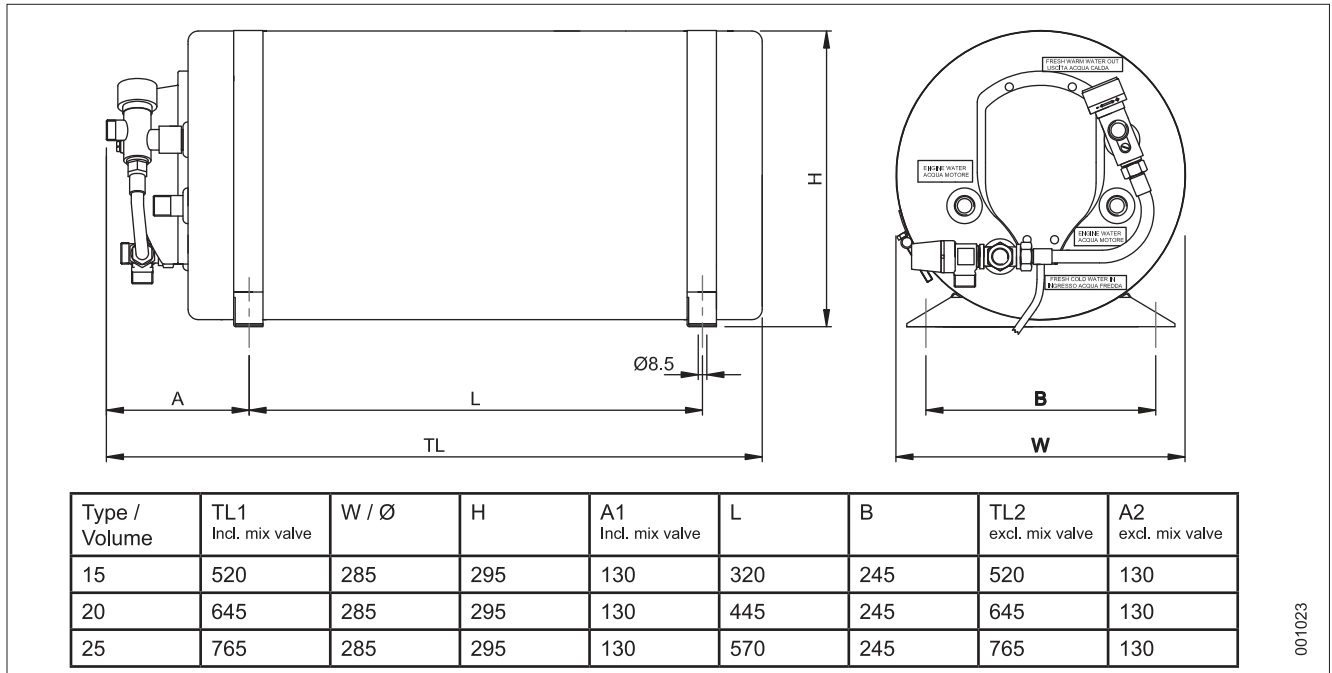

001023

Fig. 13

8.2 Slim Square

Type	Volume lit.	Weight kg / lbs	Heater element	Heater element option	Thermostat mixer valve
601631QX00000	16	15.5 / 34	230V-750W	115V-750W	-
601631QX00003	16	15.5 / 34	230V-750W	115V-750W	X

Dimensions: See fig 14
 Material: Heat exchanger coil, storage tank and connections: stainless steel AISI 316
 Outside cover and mounting brackets: Stainless steel AISI 304. Outer gables plastic.
 Heater element: Nickel plated copper
 Insulation: Polyurethane
 Safety valve: 5 bar / 73 psi

Slim Square Dimensioner

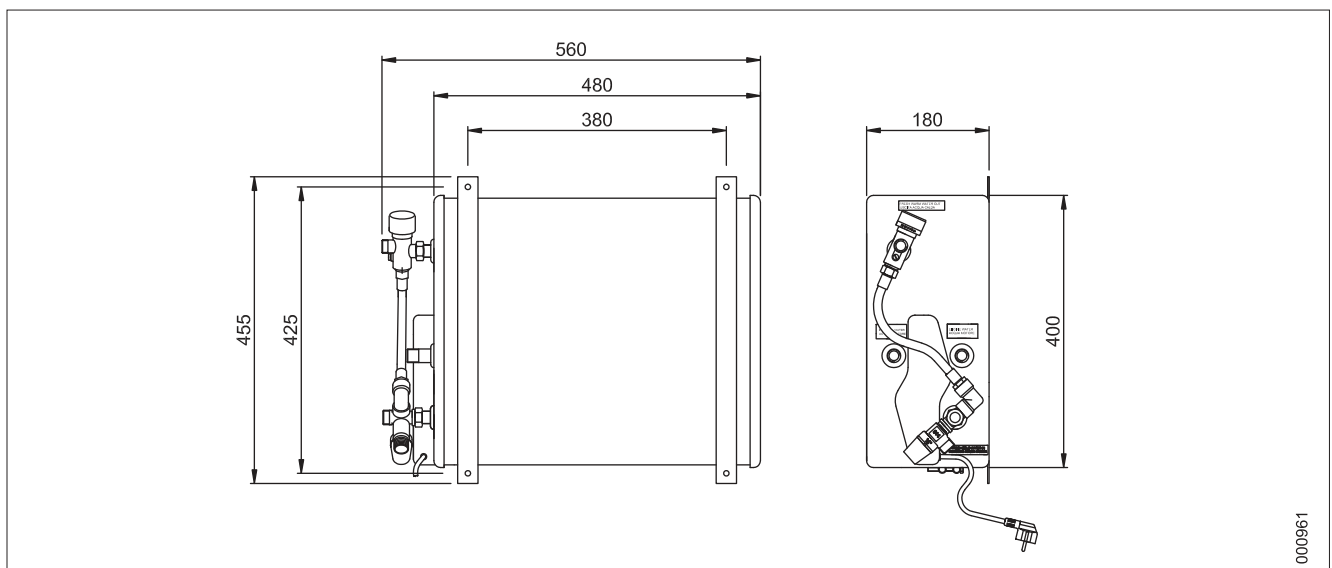

000961

Fig. 14

9. Indel Webasto Marine Warranty

The Indel Webasto Marine warranty complies with the EU directive 1999/44/EC

9.1 Period of validity

The warranty for all Isotemp water heaters is valid for 2 years concerning costs for labor for repair and replacement but only if effected by authorized service points of the IWM network.

5 years validity for leakage from the inner tank or the heat exchange coil. (labor excluded after the first 2 years).

The warranty is valid only for water heaters installed in boats, it is not valid for water heaters installed in recreational vehicles (RV) or other installations than marine.

The period of validity starts from:

- a) The sales date of the product indicated in the receipt or invoice
- b) The sales date indicated in the invoice or registration of the first sale of the boat in which the product is installed, if installed by the producer of the boat.
- c) If none of above is available, the validity starts from year and the week of production indicated in the S/N (serial number) on the label on the product.

Replacement of a product or a component does not vary the period of validity.

9.2 The warranty covers:

- Replacement or repair of the product or one or more components recognized as defect by production failure.
- Breakage or dysfunction of components within the validity of the warranty in spite of proven correct installation and correct usage.
- Labor and travel on basis of the Operation Procedures in this document.
- Costs for shipment of the product in replacement (except ev. costs for custom clearance)

9.3 The warranty does not cover defects or damage caused by:

- negligence or carelessness or misuse
- wrong installation or incautious handling
- wrong electrical connections
- undersized cables
- inaccurate maintenance or maintenance effected by not authorized personnel
- lack of observation of the instructions indicated in the dedicated user's manual
- transport damages
- products installed elsewhere than in boats
- leakage of water from boilers in which it has been used not pure water or not freshwater or water with high electrical conductivity or high salt content.
- costs for custom clearance
- professional use
- damage caused by weathering
- costs for dismantling and/or re-mounting of furniture or other structures

9.4 Info necessary to establish if a case is covered by the warranty:

- Part number (written on the label on the product)
- S/N (serial number) (written on the label on the product)
- Invoice, receipt or registration document (see point regarding validity)
- Type of boat
- Detailed description of the defect. (If possible enclose pictures)
- Description of the installation. (If possible enclose pictures)

(In case it is established that the case is not covered by the warranty, the customer must pay for eventual repair, replacement, labor, travel and transport. IWM is not obliged to cover any costs.)

9.5 Operation Procedures to apply once established that the case is covered by the warranty

Warranty interventions must only be made by service partners of IWM (see list on www.indelwebastomarine.com) IWM does not cover costs of interventions made by others.

The technician of the service point authorized by IWM goes on board if the boat is situated max 100 km from the service point. IWM covers the cost of such travel. If the boat is more than 100 Km away from the service point, the boat owner can chose to pay the technician for the travel (payment directly to the technician) or move the boat closer.

IWM does not reimburse any money for spare parts bought elsewhere than from IWM or an official IWM Distributor.



indel
Webasto
Marine

Zona Artigianale sn
I-47866 S. Agata Feltria (RN) Italy
Tel. +39 0541 848 030
Fax +39 0541 848 563

E-mail: info@indelwebastomarine.com
www.indelwebastomarine.com